

# BLANCHARD QUIET ZONE (LEGG RD & COLONY RD CROSSINGS)

ES20830-3 \ ES20830-3A

FEDERAL AID NO.: N/A

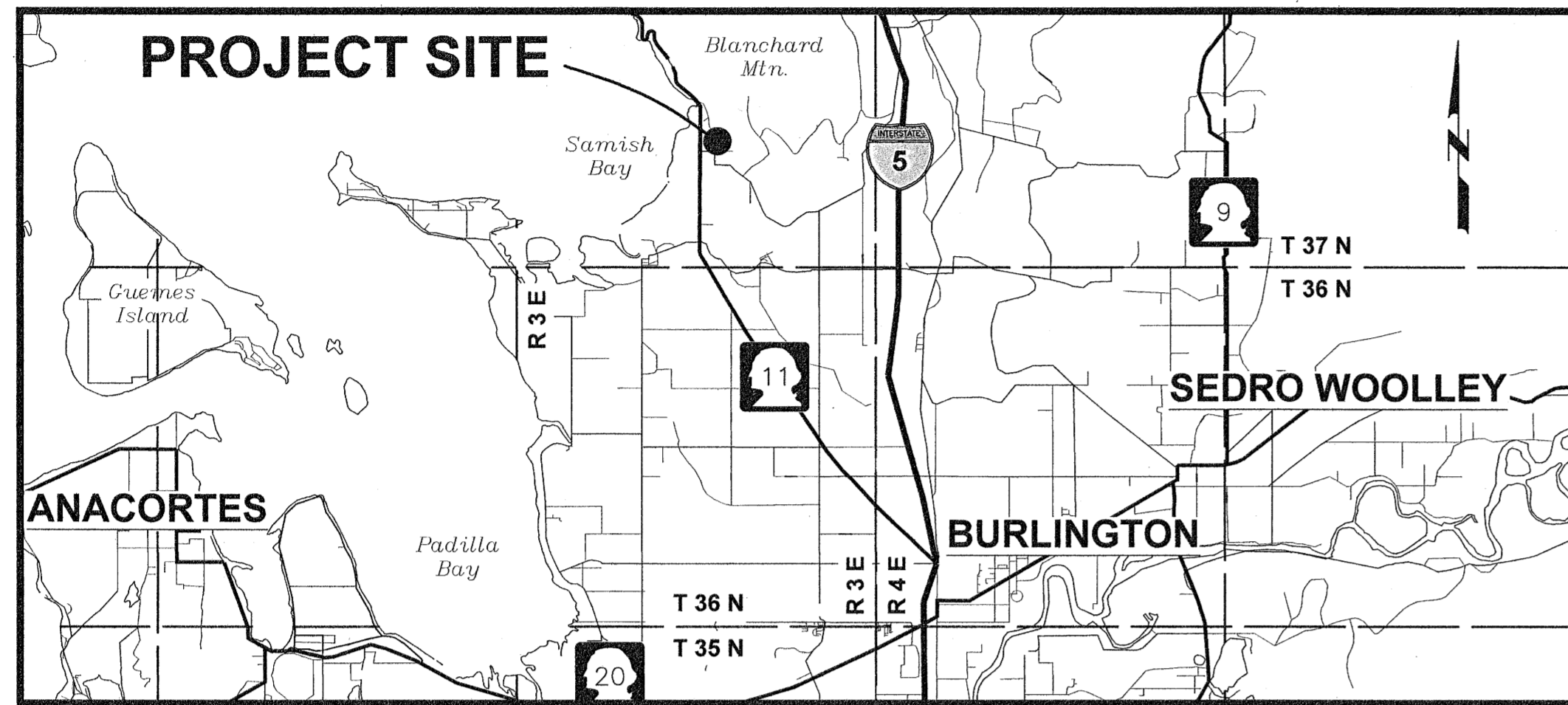

## PLAN SHEET INDEX

SHEET	TITLE
1	COVER, LEGEND
2	ROAD SECTIONS
3-5	CURB & SIGNING PLANS
6	CURB DETAILS



## SKAGIT COUNTY OFFICIALS

- BOARD OF COMMISSIONERS
- RON WESEN, CHAIR
  - KENNETH A. DAHLSTEDT, COMMISSIONER
  - LISA JANICKI, COMMISSIONER
- PUBLIC WORKS
- DAN BERENTSON, DIRECTOR

*Paul A. Randall-Grutter* 11.27.17  
 PAUL A. RANDALL-GRUTTER, P.E., COUNTY ENGINEER DATE

## T. 37N R. 3E W.M., SECTIONS 22 & 27.

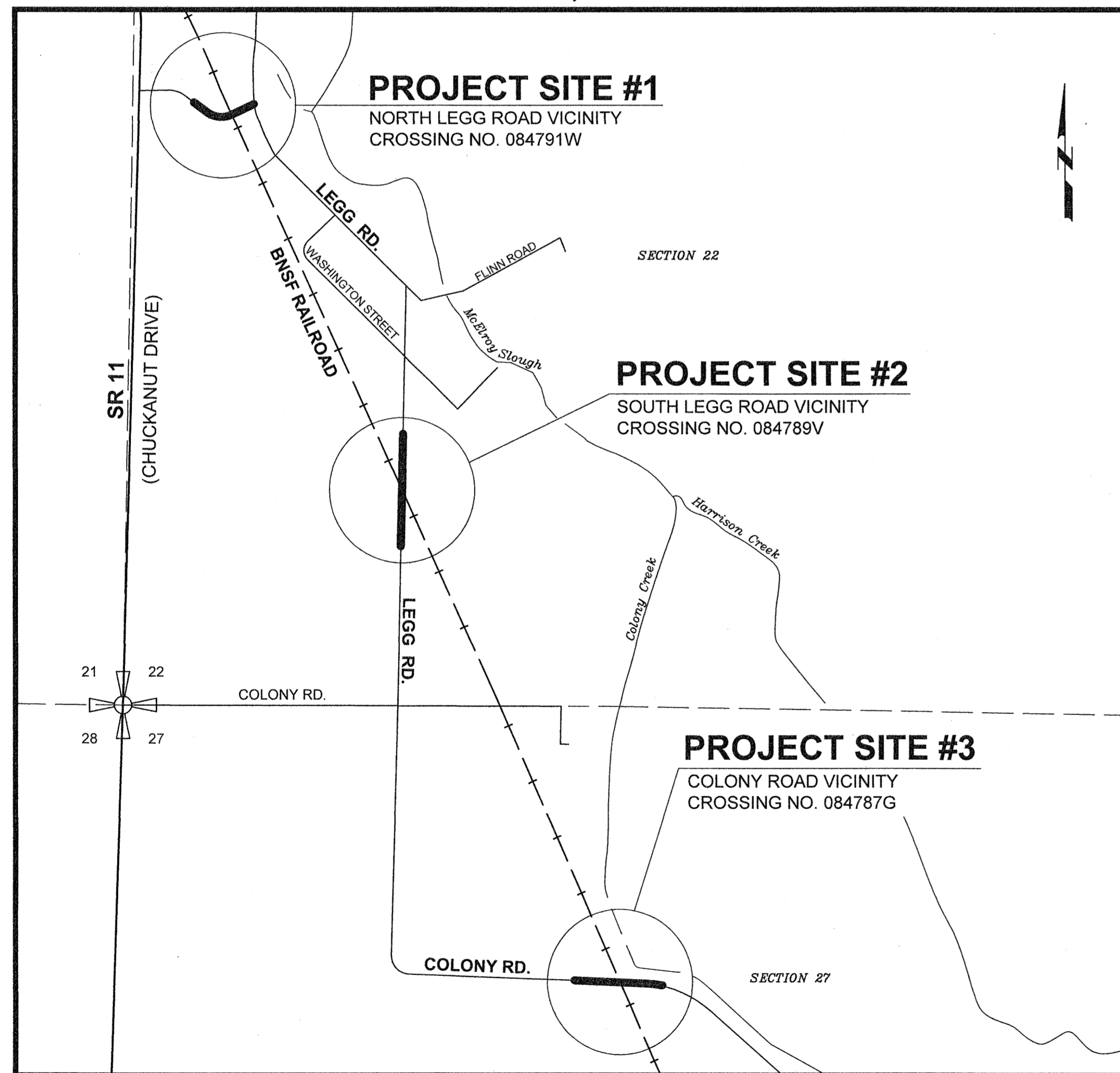

VICINITY MAP NTS

SUMMARY OF QUANTITIES			
Item #	Qty.	Unit	Item Description
1	1	LS	MOBILIZATION
2	30	CY	BALLAST
3	560	LF	DUAL-FACED CEMENT CONC. TRAFFIC CURB
4	56	EA	VERTICAL PANEL
5	560	LF	PAINTING CURB
6	200	LF	PAINT REMOVAL
7	18	EA	PERMANENT SIGNING
8	9	EA	4x4 TIMBER SIGN POST
9	1	LS	ROADSIDE CLEANUP
10	1	LS	REIMBURSEMENT FOR THIRD PARTY DAMAGE
11	2	DAY	RAILROAD FLAGGING
12	1	LS	SPCC

## LEGEND

- EXISTING EDGE OF PAVEMENT
- EXISTING EDGE OF SHOULDER
- EXISTING CONCRETE PAD
- EXISTING RAILROAD TRACKS
- x-x-x-x-x- EXISTING RAILROAD GATE
- EXISTING GUARDRAIL
- ▲ EXISTING SIGN
- EXISTING POWER POLE
- FILL — GRADING / FILL LIMITS
- EXISTING PAVEMENT MARKINGS
- EXISTING POWER POLE
- PROPOSED CURB
- NEW SIGN

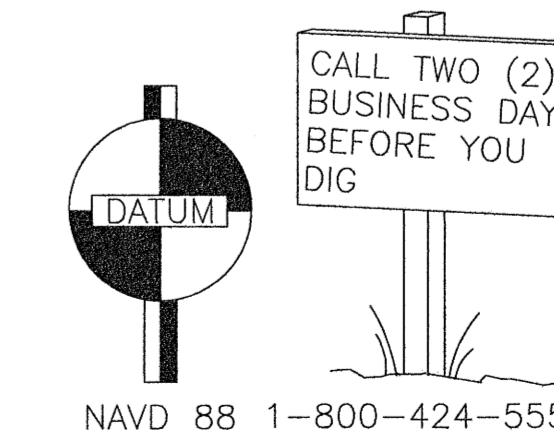

NAVD 88 1-800-424-5555

**SKAGIT COUNTY PUBLIC WORKS**  
 1800 CONTINENTAL PLACE  
 MOUNT VERNON, WA 98273-5625  
 (360) 416-1400 FAX (360) 416-1405

NO.	REVISIONS	DATE

PROJECT NO.: ES20830-3 \ ES20830-3A  
 FED. AID NO.: N/A  
 DESIGNED BY: SA  
 DRAWN BY: SA  
 CHECKED BY: FJ  
 APPROVED BY:

PROJECT LOCATED NEAR:  
 BOW, WA  
 TOWNSHIP 36 RANGE 3 EAST SECTIONS 22 & 27

**BLANCHARD QUIET ZONE  
 LEGG RD & COLONY RD  
 CROSSINGS**

INDEX / VICINITY / SOQ / LEGEND

1 INCH SCALE BAR  
 ADJUST SCALE ACCORDINGLY

SHEET  
**1 OF 6**

# BLANCHARD QUIET ZONE (LEGG RD & COLONY RD CROSSINGS)

ES20830-3 \ ES20830-3A

FEDERAL AID NO.: N/A

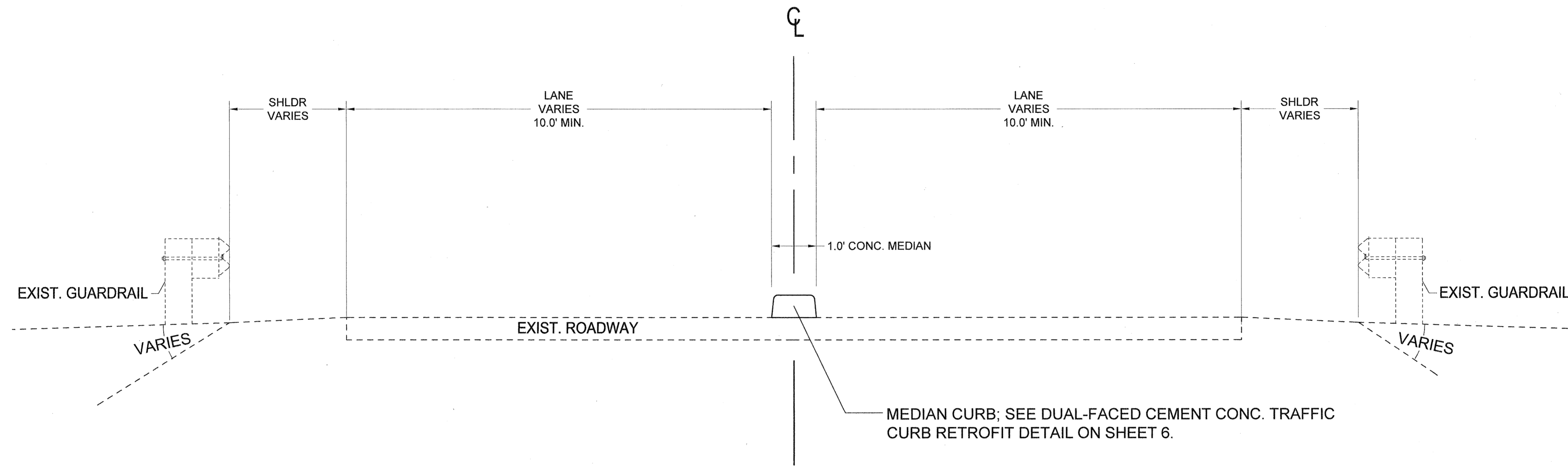

## ROADWAY SECTION A

- N. LEGG RD. MP 0.055 TO MP 0.074
- N. LEGG RD. MP 0.080 TO MP 0.092
- S. LEGG RD. MP 0.501 TO MP 0.520
- S. LEGG RD. MP 0.555 TO MP 0.574
- COLONY RD. MP 0.661 TO MP 0.680
- COLONY RD. MP 0.686 TO MP 0.705

**SKAGIT COUNTY  
PUBLIC WORKS**  
1800 CONTINENTAL PLACE  
MOUNT VERNON, WA 98273-9525  
(360) 416-1400 FAX (360) 416-1405

NO.	REVISIONS	DATE

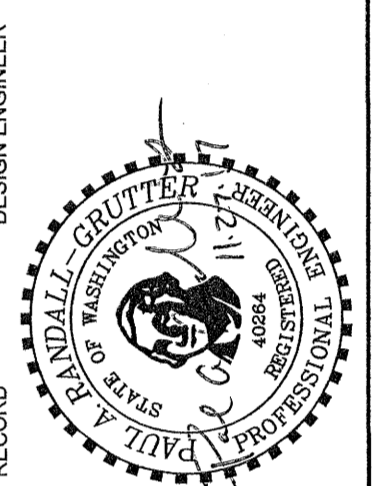

PROJECT NO.: ES20830-3 \ ES20830-3A	DESIGNED BY: SA	DRAWN BY: SA
FED. AID NO.: N/A	CHECKED BY: FJ	APPROVED BY:
PROJECT LOCATED NEAR: BOW, WA		
TOWNSHIP 36 RANGE 3 EAST SECTIONS 22 & 27		

**BLANCHARD QUIET ZONE  
LEGG RD & COLONY RD  
CROSSINGS**  
ROADWAY SECTIONS

1 INCH SCALE BAR  
ADJUST SCALE ACCORDINGLY  
SHEET  
**2 OF 6**

# BLANCHARD QUIET ZONE (LEGG RD & COLONY RD CROSSINGS)

ES20830-3 \ ES20830-3A

FEDERAL AID NO.: N/A

## GENERAL NOTES

- FOR MEDIAN CURB DETAILS, SEE DUAL-FACED CEMENT CONC. TRAFFIC CURB DETAIL ON SHEET 6.
- THE MEDIAN CURB OVERALL LENGTH SHALL BE DETERMINED BY THE FIXED POINT AS IDENTIFIED IN THE PLANS BELOW. THIS FIXED POINT IS WHERE THE RAILROAD CROSSING GATE INTERSECTS THE ROADWAY CENTERLINE AND IT SHALL BE ESTABLISHED IN THE FIELD BY THE PROJECT ENGINEER PRIOR TO BEGINNING CONSTRUCTION OF THE CURB. THE OVERALL LENGTH CALLED OUT IN THE PLANS BELOW SHALL BE DEFINED FROM THIS ESTABLISHED POINT.
- VERTICAL PANEL TYPE, SHEETING & HARDWARE SHALL BE APPROVED BY THE PROJECT ENGINEER PRIOR TO USE.
- VERTICAL PANELS SHALL BE ANCHORED TO THE CURB AND PLACED EVERY 10.0' O.C.
- FOR TYPICAL VERTICAL PANEL DIMENSIONS, SEE VERTICAL PANEL DETAIL ON THIS SHEET. ALTERNATE PANEL TYPES MAY BE USED BUT SHALL REQUIRE PROJECT ENGINEER APPROVAL PRIOR TO INSTALLATION.
- FOR SIGN INSTALLATION LOCATION REQUIREMENTS SEE WSDOT STANDARD PLAN G-20.10-00.
- FOR TIMBER SIGN SUPPORT INSTALLATION, SEE WSDOT STANDARD PLAN G-22.10-01, SINGLE POST INSTALLATION.
- SIGN SHALL BE COVERED UPON COMPLETION OF INSTALLATION. SIGN SHALL BE UNCOVERED 48 HOURS AFTER THE QUIET ZONE HAS BEEN OFFICIALLY ESTABLISHED.
- FILL MATERIAL SHALL BE CRUSHED SURFACING BASE COURSE. APPROXIMATELY 10 CY SHALL BE PLACED IN THE LOCATION OUTLINED ABOVE TO EXTEND THE EXISTING SHOULDER OUT IN LINE WITH THE EXISTING UTILITY POLE SHOWN IN THE PLANS. THE FILL LIMITS SHALL BE MARKED BY THE PROJECT ENGINEER PRIOR TO FILL BEING PLACED. PLACED FILL SHALL BE COMPACTED TO 95% COMPACTION, AS DETERMINED BY THE PROJECT ENGINEER. NO SENSITIVE AREAS SHALL BE IMPACTED.

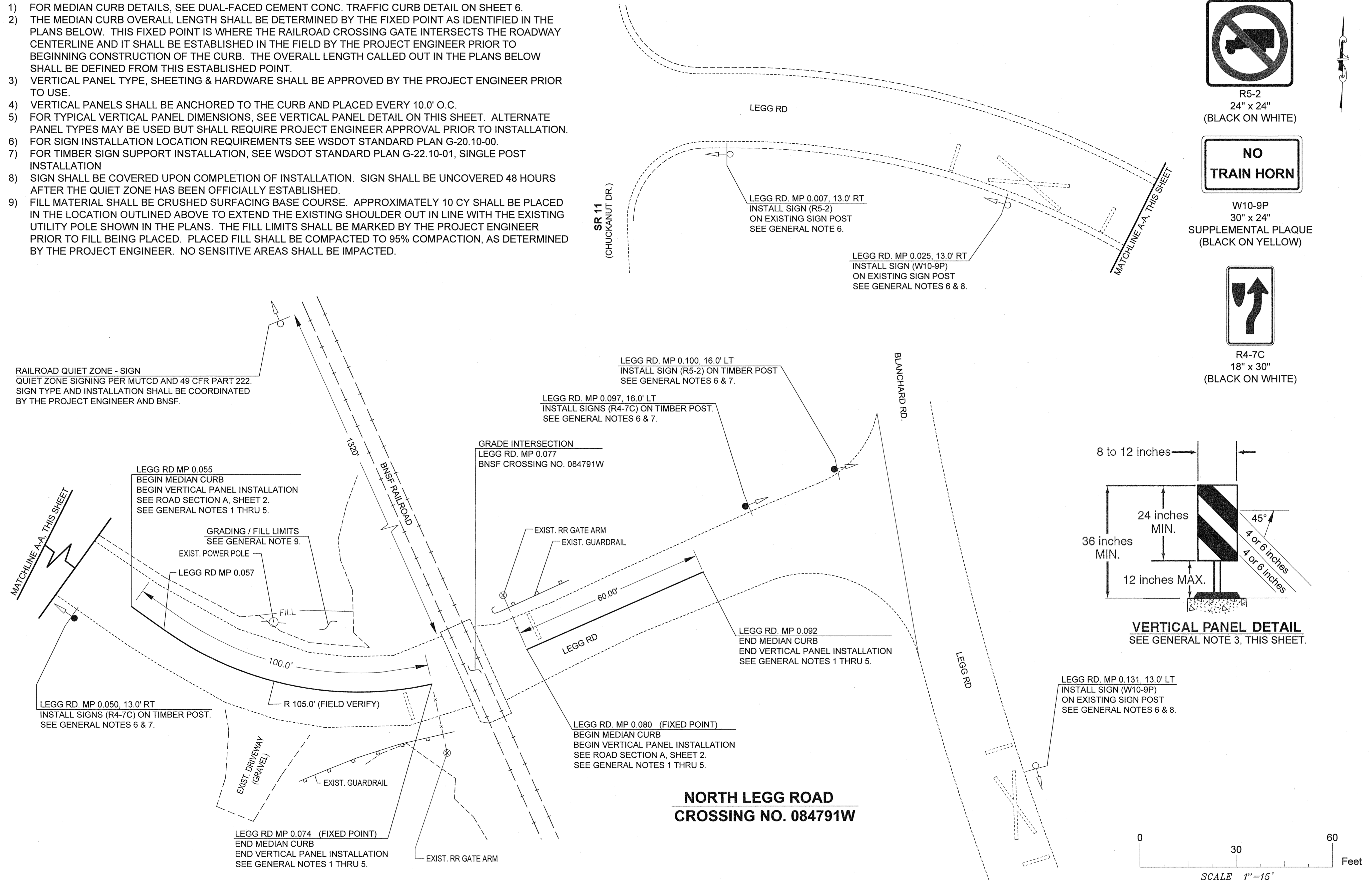

R5-2  
24" x 24"  
(BLACK ON WHITE)



W10-9P  
30" x 24"  
SUPPLEMENTAL PLAQUE  
(BLACK ON YELLOW)

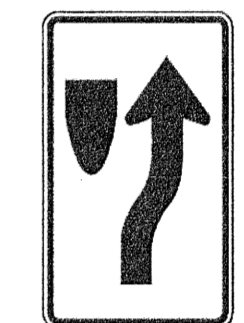

R4-7C  
18" x 30"  
(BLACK ON WHITE)

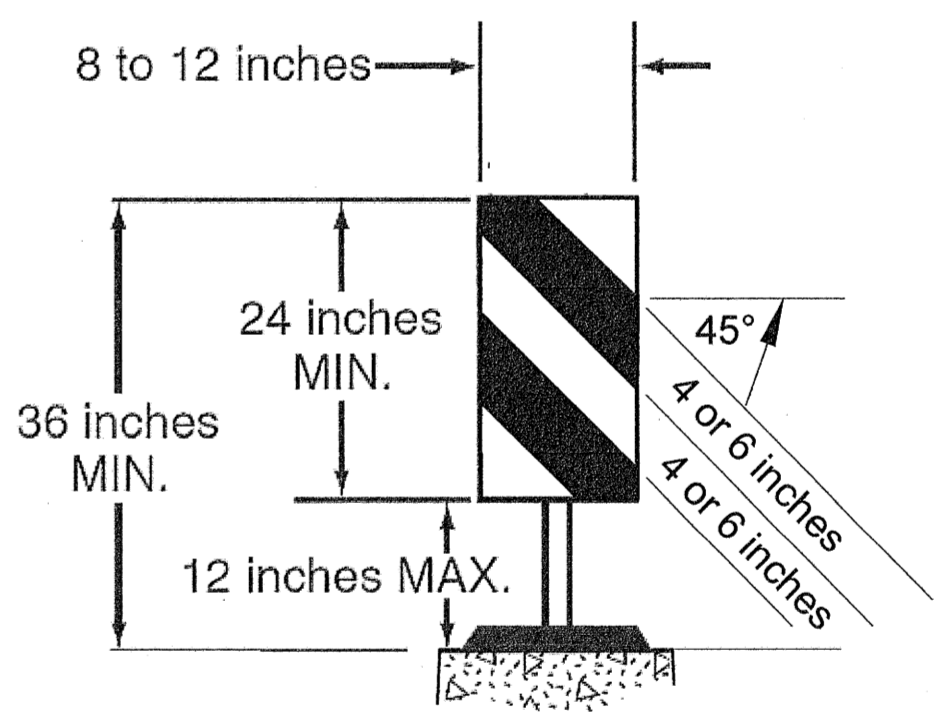

**VERTICAL PANEL DETAIL**  
SEE GENERAL NOTE 3, THIS SHEET.

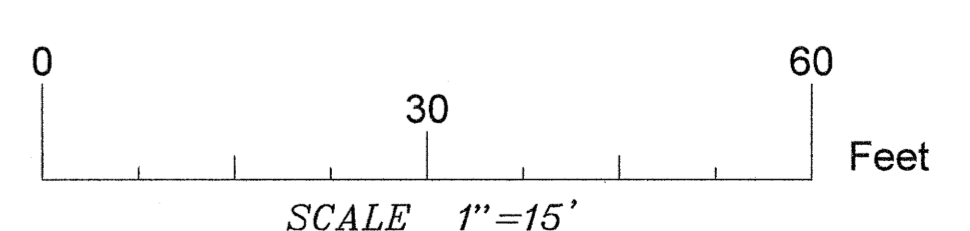

<b>SKAGIT COUNTY PUBLIC WORKS</b> 1800 CONTINENTAL PLACE MOUNT VERNON, WA 98273-5625 (360) 416-1400 FAX (360) 416-1405		DATE
		NO.
		REVISIONS
PROJECT NO.: ES20830-3   ES20830-3A FED. AID NO.: N/A DESIGNED BY: SA CHECKED BY: SA DRAWN BY: SA APPROVED BY: SA PROJECT LOCATED NEAR: BOW, WA TOWNSHIP 36 RANGE 3 EAST SECTIONS 22 & 27		
<b>BLANCHARD QUIET ZONE LEGG RD &amp; COLONY RD CROSSINGS</b> NORTH LEGG ROAD BNSF CROSSING NO. 084791W		
1 INCH SCALE BAR ADJUST SCALE ACCORDINGLY		
SHEET <b>3 OF 6</b>		

# BLANCHARD QUIET ZONE (LEGG RD & COLONY RD CROSSINGS)

ES20830-3 \ ES20830-3A

FEDERAL AID NO.: N/A

## GENERAL NOTES

- FOR MEDIAN CURB DETAILS, SEE DUAL-FACED CEMENT CONC. TRAFFIC CURB DETAIL ON SHEET 6.
- THE MEDIAN CURB OVERALL LENGTH SHALL BE DETERMINED BY THE FIXED POINT AS IDENTIFIED IN THE PLANS BELOW. THIS FIXED POINT IS WHERE THE RAILROAD CROSSING GATE INTERSECTS THE ROADWAY CENTERLINE AND IT SHALL BE ESTABLISHED IN THE FIELD BY THE PROJECT ENGINEER PRIOR TO BEGINNING CONSTRUCTION OF THE CURB. THE OVERALL LENGTH CALLED OUT IN THE PLANS BELOW SHALL BE DEFINED FROM THIS ESTABLISHED POINT.
- VERTICAL PANEL TYPE, SHEETING & HARDWARE SHALL BE APPROVED BY THE PROJECT ENGINEER PRIOR TO USE.
- VERTICAL PANELS SHALL BE ANCHORED TO THE CURB AND PLACED EVERY 10.0' O.C.
- FOR TYPICAL VERTICAL PANEL DIMENSIONS, SEE VERTICAL PANEL DETAIL ON THIS SHEET. ALTERNATE PANEL TYPES MAY BE USED BUT SHALL REQUIRE PROJECT ENGINEER APPROVAL PRIOR TO INSTALLATION.
- FOR SIGN INSTALLATION LOCATION REQUIREMENTS SEE WSDOT STANDARD PLAN G-20.10-00.
- FOR TIMBER SIGN SUPPORT INSTALLATION, SEE WSDOT STANDARD PLAN G-22.10-01, SINGLE POST INSTALLATION
- SIGN SHALL BE COVERED UPON COMPLETION OF INSTALLATION. SIGN SHALL BE UNCOVERED 48 HOURS AFTER THE QUIET ZONE HAS BEEN OFFICIALLY ESTABLISHED.
- FILL MATERIAL SHALL BE CRUSHED SURFACING BASE COURSE. APPROXIMATELY 10 CY SHALL BE PLACED IN THE LOCATION OUTLINED ABOVE TO EXTEND THE EXISTING SHOULDER OUT IN LINE WITH THE EXISTING UTILITY POLE SHOWN IN THE PLANS. THE FILL LIMITS SHALL BE MARKED BY THE PROJECT ENGINEER PRIOR TO FILL BEING PLACED. PLACED FILL SHALL BE COMPACTED TO 95% COMPACTION, AS DETERMINED BY THE PROJECT ENGINEER. NO SENSITIVE AREAS SHALL BE IMPACTED.

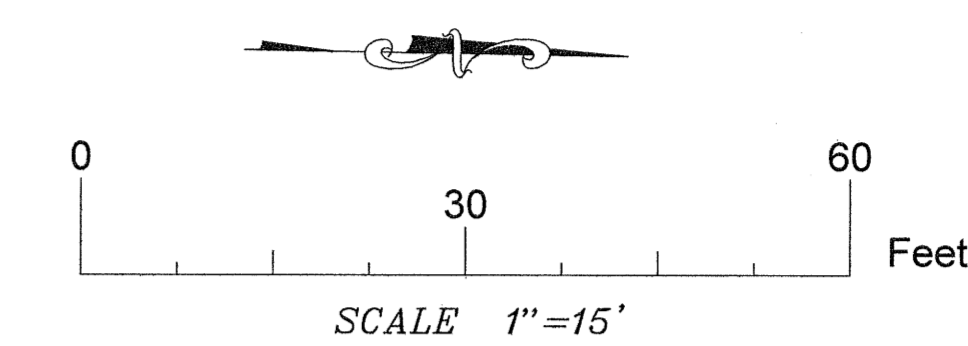
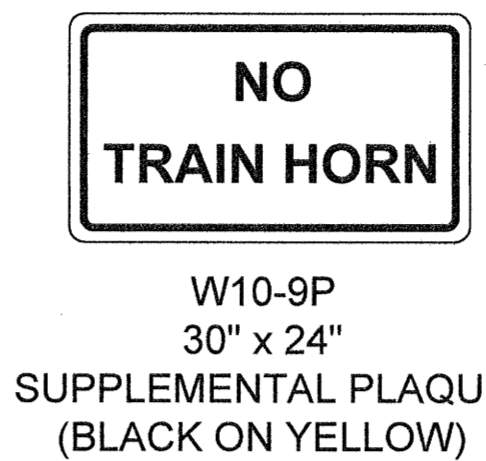
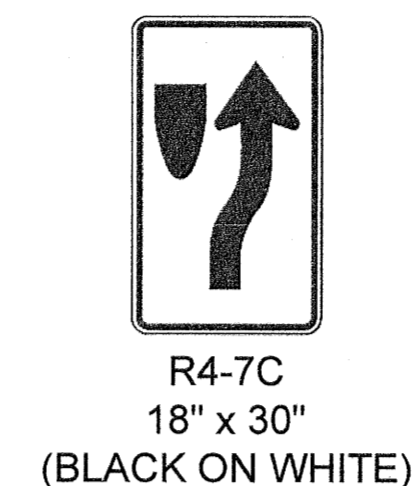

**SKAGIT COUNTY  
PUBLIC WORKS**  
1800 CONTINENTAL PLACE  
MOUNT VERNON, WA 98273-5625  
(360) 416-1400 FAX (360) 416-1405

NO.	REVISIONS	DATE



PROJECT NO.: ES20830-3	ES20830-3A
FED. AID NO.: N/A	
DESIGNED BY: SA	DRAWN BY: SA
CHECKED BY: FJ	APPROVED BY:
PROJECT LOCATED NEAR: BOW, WA	
TOWNSHIP: 36 RANGE 3 EAST SECTIONS 22 & 27	

**BLANCHARD QUIET ZONE  
LEGG RD & COLONY RD  
CROSSINGS**  
SOUTH LEGG ROAD  
BNSF CROSSING NO. 084789V

1 INCH SCALE BAR  
ADJUST SCALE ACCORDINGLY

SHEET  
**4 OF 6**

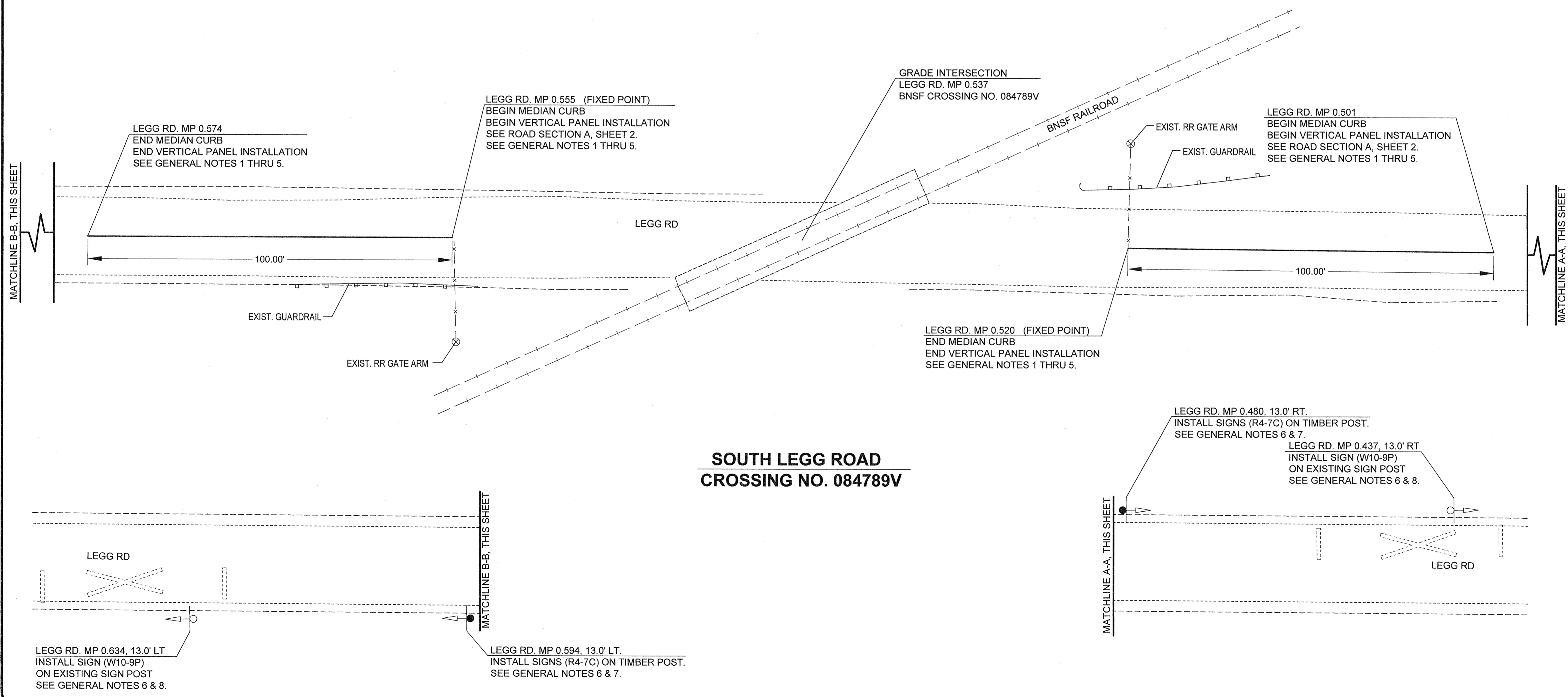

# BLANCHARD QUIET ZONE (LEGG RD & COLONY RD CROSSINGS)

ES20830-3 \ ES20830-3A

FEDERAL AID NO.: N/A

## GENERAL NOTES

- FOR MEDIAN CURB DETAILS, SEE DUAL-FACED CEMENT CONC. TRAFFIC CURB DETAIL ON SHEET 6.
- THE MEDIAN CURB OVERALL LENGTH SHALL BE DETERMINED BY THE FIXED POINT AS IDENTIFIED IN THE PLANS BELOW. THIS FIXED POINT IS WHERE THE RAILROAD CROSSING GATE INTERSECTS THE ROADWAY CENTERLINE AND IT SHALL BE ESTABLISHED IN THE FIELD BY THE PROJECT ENGINEER PRIOR TO BEGINNING CONSTRUCTION OF THE CURB. THE OVERALL LENGTH CALLED OUT IN THE PLANS BELOW SHALL BE DEFINED FROM THIS ESTABLISHED POINT.
- VERTICAL PANEL TYPE, SHEETING & HARDWARE SHALL BE APPROVED BY THE PROJECT ENGINEER PRIOR TO USE.
- VERTICAL PANELS SHALL BE ANCHORED TO THE CURB AND PLACED EVERY 10.0' O.C.
- FOR TYPICAL VERTICAL PANEL DIMENSIONS, SEE VERTICAL PANEL DETAIL ON THIS SHEET. ALTERNATE PANEL TYPES MAY BE USED BUT SHALL REQUIRE PROJECT ENGINEER APPROVAL PRIOR TO INSTALLATION.
- FOR SIGN INSTALLATION LOCATION REQUIREMENTS SEE WSDOT STANDARD PLAN G-20.10-00.
- FOR TIMBER SIGN SUPPORT INSTALLATION, SEE WSDOT STANDARD PLAN G-22.10-01, SINGLE POST INSTALLATION.
- SIGN SHALL BE COVERED UPON COMPLETION OF INSTALLATION. SIGN SHALL BE UNCOVERED 48 HOURS AFTER THE QUIET ZONE HAS BEEN OFFICIALLY ESTABLISHED.
- FILL MATERIAL SHALL BE CRUSHED SURFACING BASE COURSE. APPROXIMATELY 10 CY SHALL BE PLACED IN THE LOCATION OUTLINED ABOVE TO EXTEND THE EXISTING SHOULDER OUT IN LINE WITH THE EXISTING UTILITY POLE SHOWN IN THE PLANS. THE FILL LIMITS SHALL BE MARKED BY THE PROJECT ENGINEER PRIOR TO FILL BEING PLACED. PLACED FILL SHALL BE COMPACTED TO 95% COMPACTION, AS DETERMINED BY THE PROJECT ENGINEER. NO SENSITIVE AREAS SHALL BE IMPACTED.

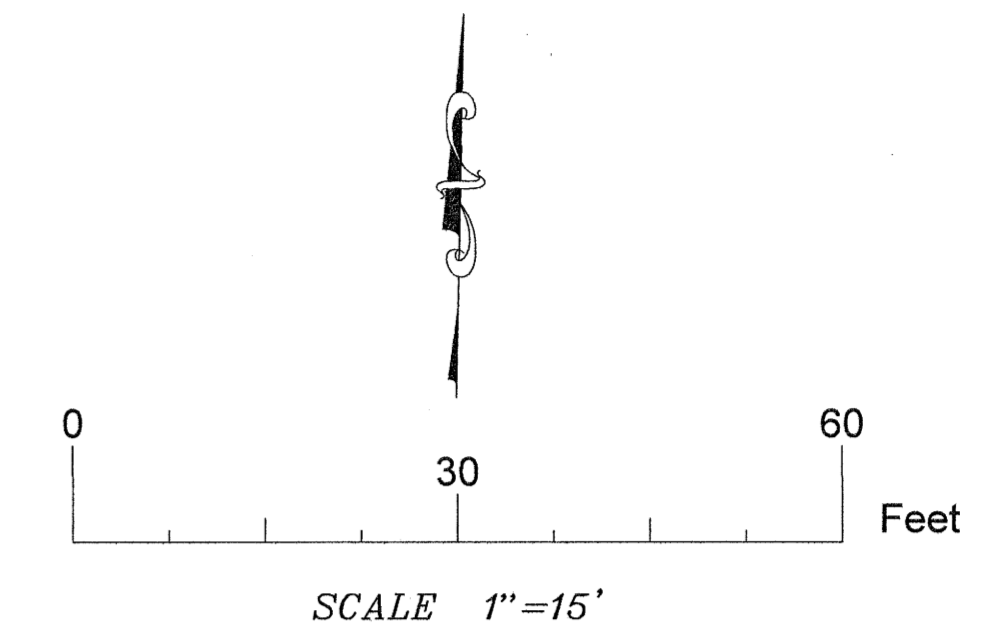
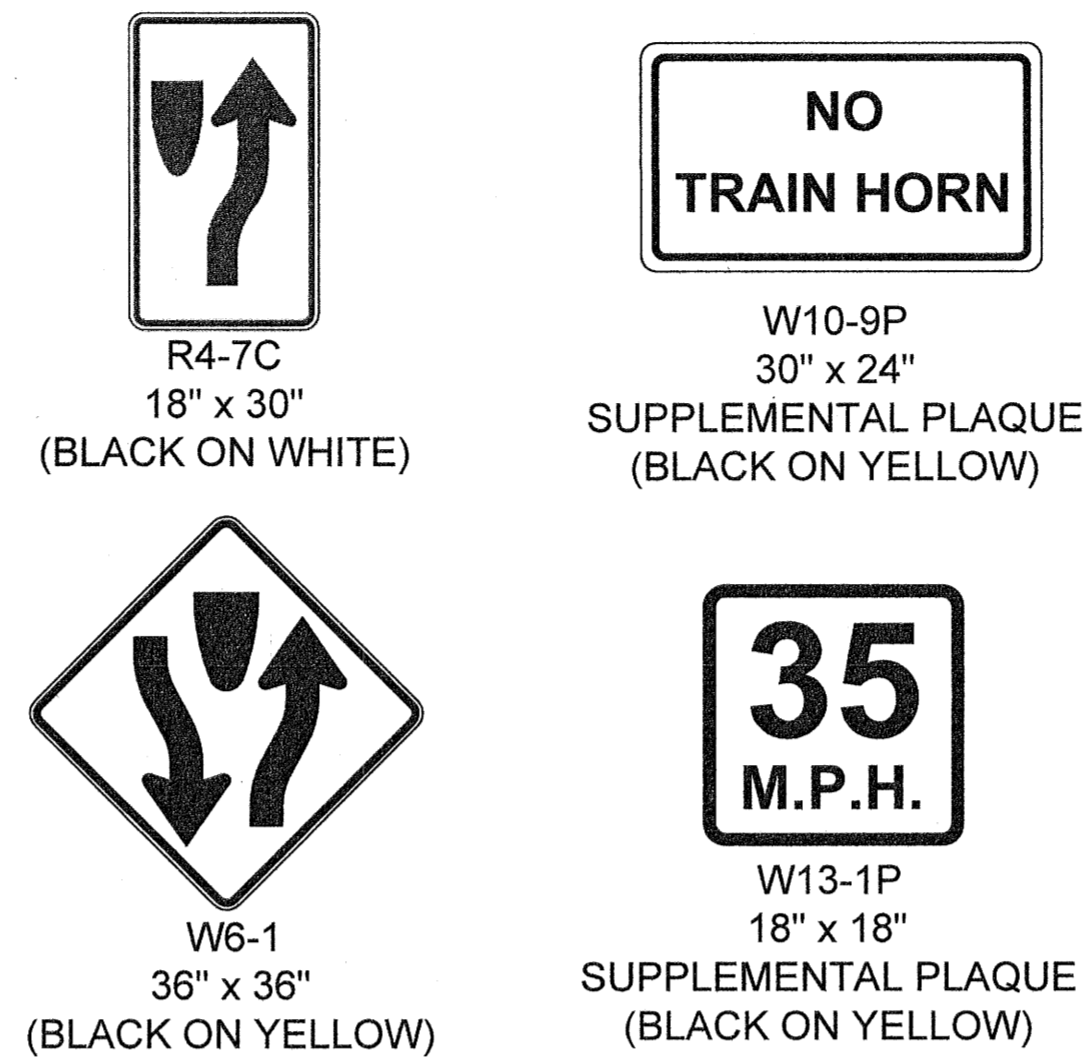

**SKAGIT COUNTY PUBLIC WORKS**  
1800 CONTINENTAL PLACE  
MOUNT VERNON, WA 98273-5625  
(360) 416-1400 FAX (360) 416-1405

NO.	REVISIONS	DATE



PROJECT NO.: ES20830-3 \ ES20830-3A	DESIGNED BY: SA	DRAWN BY: SA
FED. AID NO.: N/A	CHECKED BY: FJ	APPROVED BY:
PROJECT LOCATED NEAR: BOW, WA		
TOWNSHIP 36 RANGE 3 EAST SECTIONS 22 & 27		

**BLANCHARD QUIET ZONE  
LEGG RD & COLONY RD  
CROSSINGS**  
COLONY ROAD  
BNSF CROSSING NO. 084787G

1 INCH SCALE BAR  
ADJUST SCALE ACCORDINGLY

SHEET  
**5 OF 6**

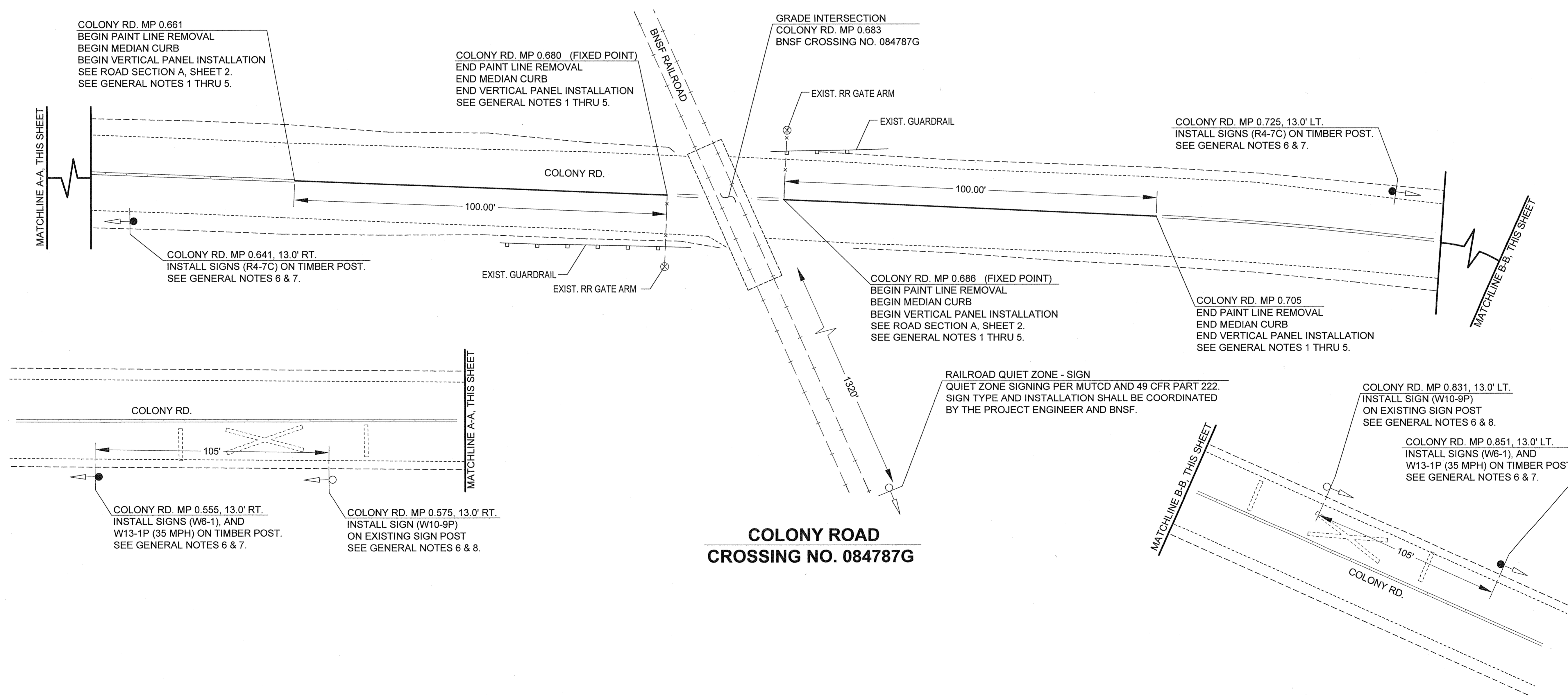

# BLANCHARD QUIET ZONE (LEGG RD & COLONY RD CROSSINGS)

ES20830-3 \ ES20830-3A

FEDERAL AID NO.: N/A

**SKAGIT COUNTY  
PUBLIC WORKS**  
1800 CONTINENTAL PLACE  
MOUNT VERNON, WA 98273-5625  
(360) 416-1400 FAX (360) 416-1405

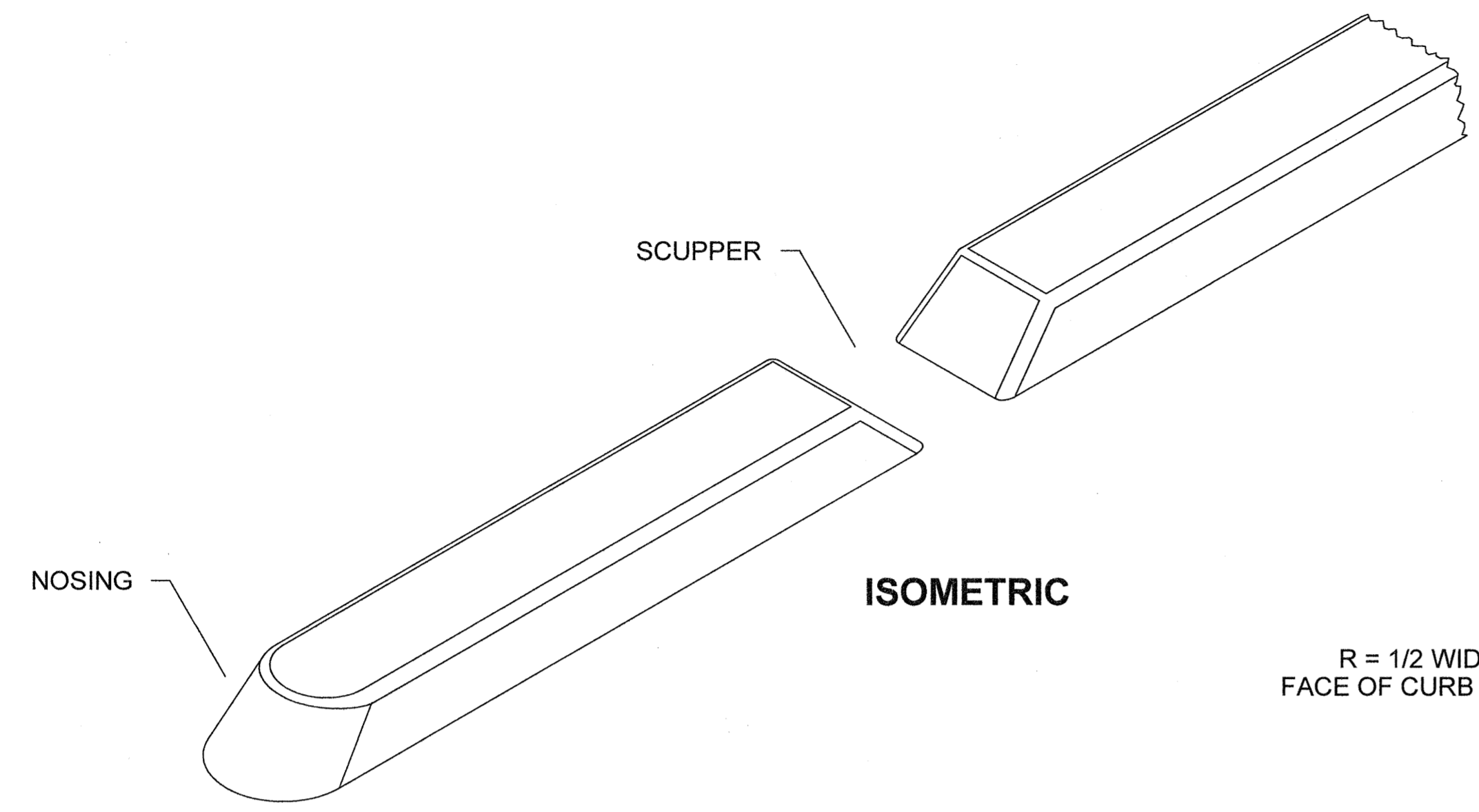

**GENERAL NOTES:**

1. EXTRUDED CONCRETE CURB SHALL BE USED AS APPROVED BY THE PROJECT ENGINEER.
2. CURB SHALL BE BONDED TO THE EXISTING ROADWAY SURFACE WITH AN APPROVED BONDING AGENT TO BE APPROVED BY THE PROJECT ENGINEER PRIOR TO USE.
3. CEMENT CONCRETE SHALL MEET OR EXCEED 4000 PSI COMPRESSIVE STRENGTH.
4. CEMENT MIX DESIGN SHALL BE SUBMITTED BY THE CONTRACTOR AND APPROVED BY THE PROJECT ENGINEER PRIOR TO USE.
5. FINISHED CURB SHALL BE PAINTED YELLOW AFTER A 28-DAY CURE TIME OF THE MEDIAN CURB.

**CONSTRUCTION NOTES:**

- 1 DRILL 3/4" (IN) DIAMETER HOLE IN THE EXISTING ROADWAY PAVEMENT.
- 2 #4 EPOXY-COATED STEEL REINFORCING BAR @ 18" (IN) O.C.
- 3 CURB TO BE GLUED/BONDED TO THE EXISTING ROADWAY SURFACE.

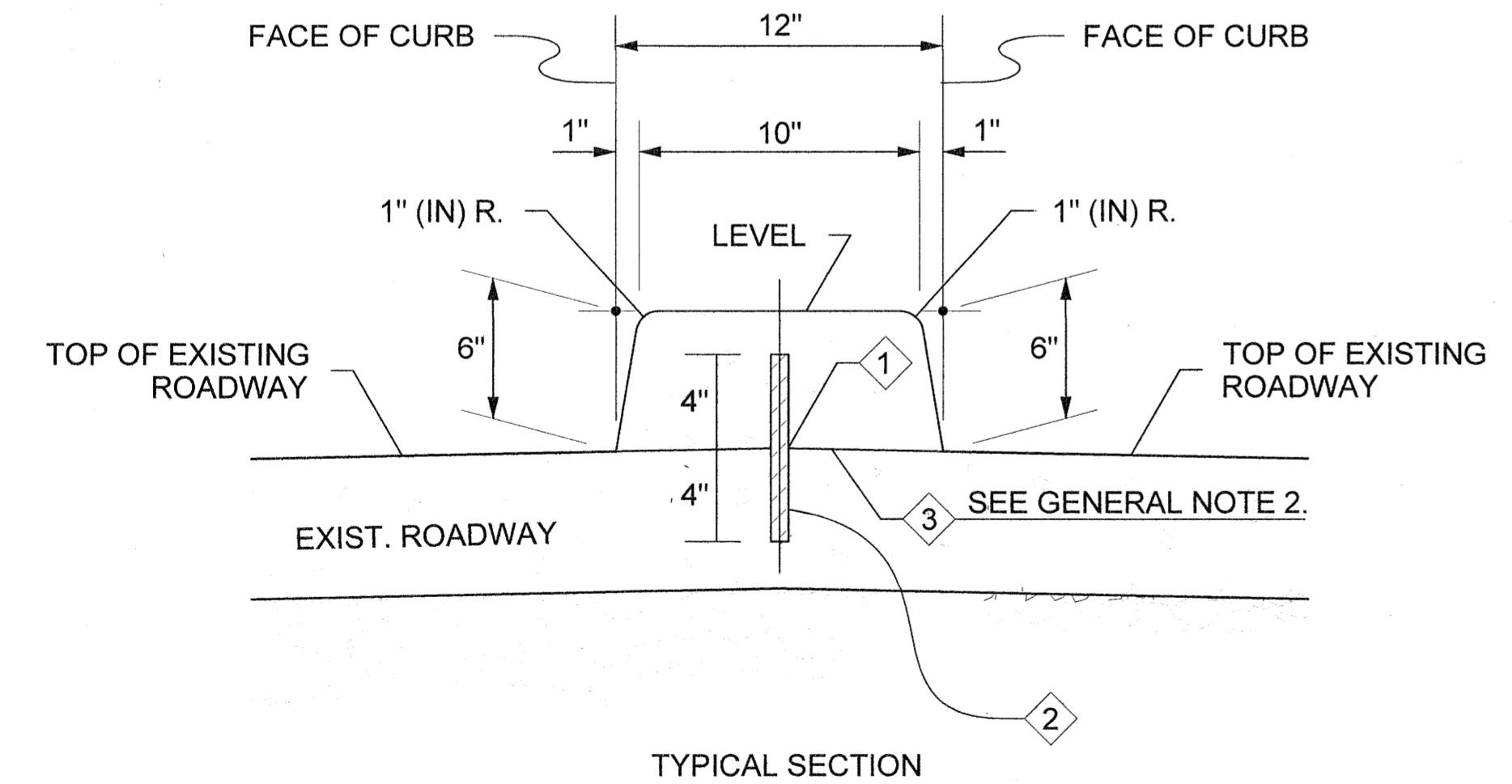

**DUAL-FACED CEMENT CONC. TRAFFIC CURB  
RETROFIT**

**ANCHORED TO EXISTING PAVEMENT**  
(SEE GENERAL NOTES 1-5, THIS SHEET)

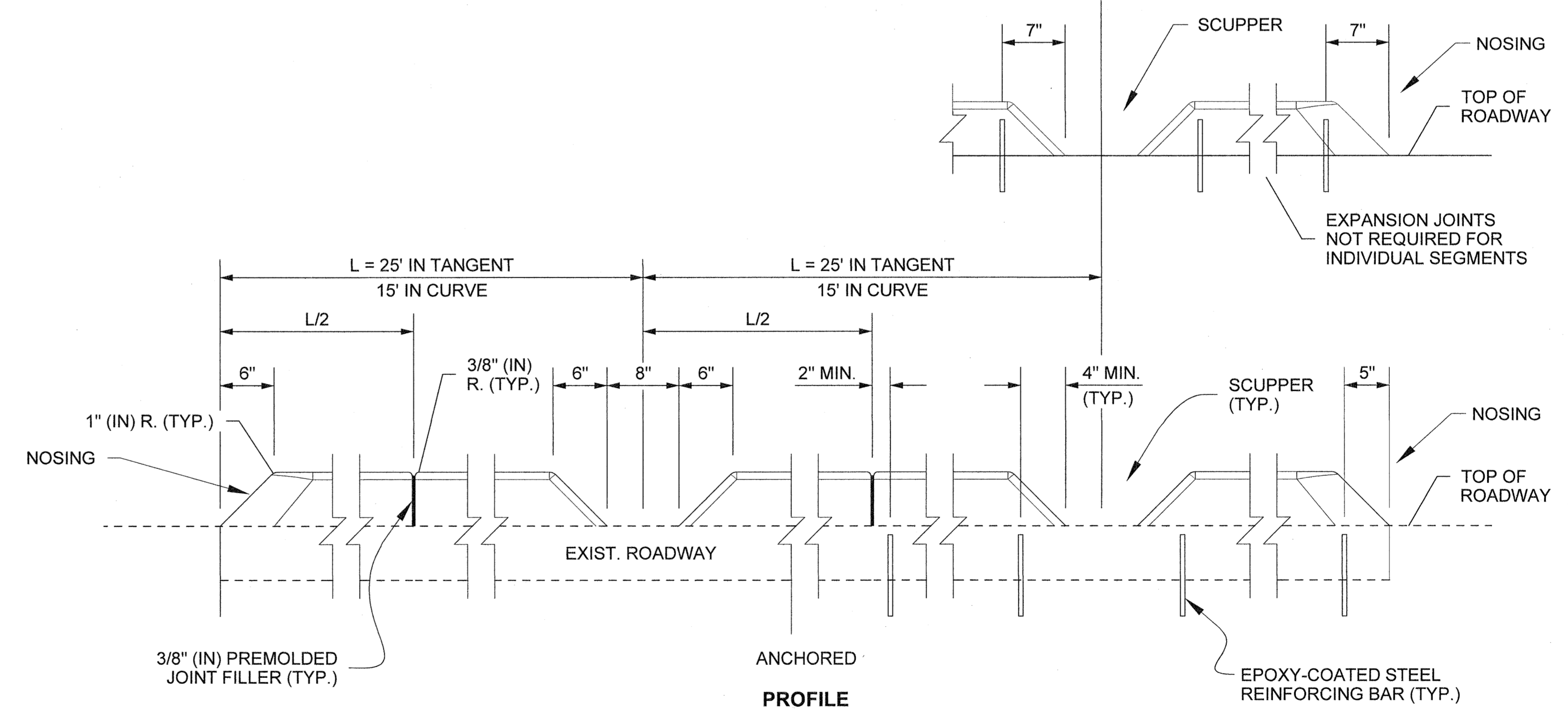
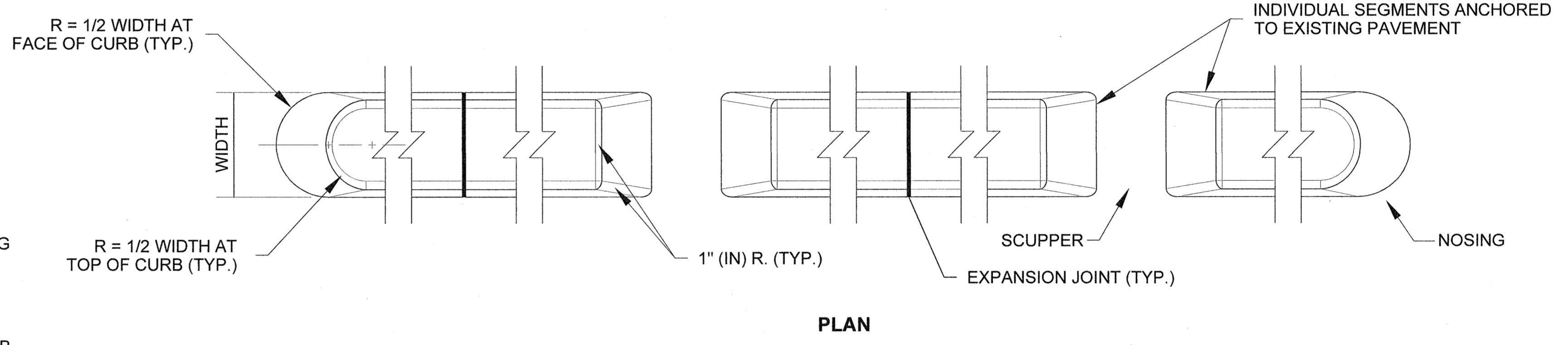

NO.	REVISIONS	DATE

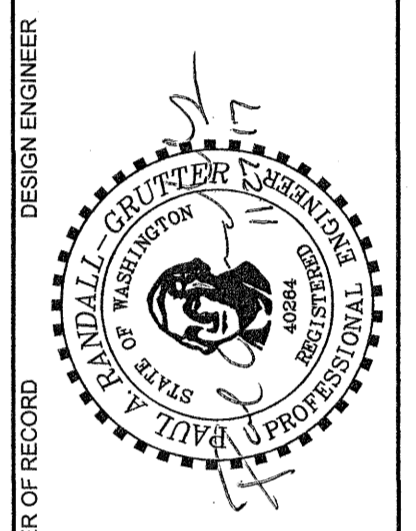

PROJECT NO.: ES20830-3 \ ES20830-3A  
FED. AID NO.: N/A  
DESIGNED BY: SA  
CHECKED BY: FJ  
DRAWN BY: SA  
APPROVED BY:  
PROJECT LOCATED NEAR:  
BOW, WA  
TOWNSHIP 36 RANGE 3 EAST SECTIONS 22 & 27

**BLANCHARD QUIET ZONE  
LEGG RD & COLONY RD  
CROSSINGS**  
CURB DETAILS

1 INCH SCALE BAR  
ADJUST SCALE ACCORDINGLY

# Contract Provisions and Plans

Blanchard Quiet Zone Median Curb  
Construction **Project #ES20830-3,  
ES20830-3A**

SMALL **PUBLIC WORKS CONTRACT**

SKAGIT COUNTY PUBLIC WORKS

Must be an approved contractor on the Municipal Research and  
Services Center (MRSC) Roster in order to Bid this  
project: <http://www.mrscrosters.org>

---

---



**BLANCHARD QUIET ZONE MEDIAN CURB  
CONSTRUCTION  
PROJECT #ES20830-3; ES20830-3A**

This contract provides for the construction and installation of Dual-Faced Cement Concrete Traffic Curb as shown in the contract plans. Extruded or other slip-based methods are encouraged. All work shall be in accordance with the attached Contract Plans, the Contract Provisions, and the 2016 Standard Specifications for Road, Bridge, and Municipal Construction.

**Schedule:** All work is to be completed within 3 working days from Notice to Proceed.





**BLANCHARD QUIET ZONE  
MEDIAN CURB CONSTRUCTION PROJECT  
#ES20830-3; ES20830-3A**

**CERTIFICATION**

We hereby certify that these contract documents were prepared by us or under our direct supervision, and that we are duly registered Professional Engineers under the laws of the State of Washington.

Engineer of Record

Design Engineer



# TABLE OF CONTENTS

---

<b>Definitions</b>	iii
<b>General Information and Contract Provisions</b>	
Project Title	1
Description of Work	1
Bid Due Date and Time	1
Engineer's Estimate	1
Upon Award of Contract	1
Notice to Proceed	2
Schedule	2
Pre-Bid Site Meeting	2
Questions and Answers	2
Addenda	2
Mandatory Bidder Responsibility Criteria	2
Interpretation of Bid and Purchase Documents	2
Title VI	2
Examination of Bid and Contract Documents, Site, and Site Conditions	3
<b>Bid Procedures and Conditions</b>	
Proposal Forms	3
Preparation of Proposal	3
Bid Price	3
Signatures	4
Delivery of Proposal	4
Withdrawal or Revision of Proposal	4
Bid Bond/Guaranty	4
Non-Collusion	4
Consideration of Bids	5
Non-Responsive Bids	5
Tied Bids	5
Irregular Proposals	5
Disqualifications of Bidders	6
Protests	6
<b>Award of Contract</b>	
Condition of Award	7
Acceptance of Award	7
Coordination of Documents	7
<b>Contract</b>	
Execution of Contract	7
Contract Documents	8
Contract Bond	8
Retainage	8

Insurance	9
Additional Insured	10
<b>Contract continued</b>	
Public Works Project – Prevailing Wage	10
Licenses and Permits	10
Subcontracting	11
Changes/Amendments	11
Warranty of Work	11
Material Approval	12
Equal Opportunity and Non-Discrimination	12
Failure to Execute Contract	12
Return of Bid Bond/Guaranty	12
<b>Legal Relations and Responsibilities to the Public</b>	
Compliance with Laws	12
Applicable Law and Forum	12
Application of Sales Tax	12
Defense & Indemnity Agreement	12
Hold Harmless	13
Safety Measures	13
Mutual Responsibility of Contractor	13
Termination for Breach and/or Default	13
Termination for Public Convenience	14
Claims and Dispute Resolution	14
<b>Payment</b>	
Invoices	15
<b>Specifications</b>	
Scope of Work	16
Anticipated Services	16
General Nature of Work	16
<b>Special Provisions</b>	
8-04.3(1) Cement Concrete Curb, Gutters, and Spillways	17
8-04.3(1)A Extruded Cement Concrete Curb	17
<b>Appendices</b>	
Appendix A – Vendor Services Agreement, Endorsement Sample, Contract Bond, Prevailing Wage Acknowledgement, and Retainage Option	A
Appendix B – Proposal Forms	B
Appendix C – Contract Plans	C

# DEFINITIONS

---

As stated in the *2016 WSDOT Standard Specifications*:

**Addendum** – A written or graphic document, issued to all Bidders and identified as an Addendum prior to Bid opening, which modifies or supplements the Bid Documents and becomes a part of the Contract.

**Award** – The formal decision of the Contracting Agency to accept the lowest responsible and responsive Bidder for the Work.

**Bid, Proposal** – The offer of a Bidder on a properly completed Proposal Form to perform the Contract.

**Bidder** – An individual, partnership, firm, corporation, or joint venture, submitting a Proposal or Bid. When required by law or otherwise the individual, partnership, firm, corporation, or joint venture shall be prequalified.

**Bid Documents** – The component parts of the proposed Contract which may include, but are not limited to, the Proposal Form, the proposed Contract Provisions, the proposed Contract Plans, Addenda, and for projects with Contracting Agency subsurface investigations; the Summary of Geotechnical Conditions and subsurface boring logs (if any).

**Contract** – The written agreement between the Contracting Agency and the Contractor. It describes, among other things:

1. What work will be done, and by when;
2. Who provides labor and materials; and
3. How Contractors will be paid.

The Contract includes the Contract (agreement) Form, Bidder's completed Proposal Form, Contract Provisions, Contract Plans, Special Provisions, *Standard Specifications*, *Standard Plans*, Addenda, various certifications and affidavits, supplemental agreements, change orders, and subsurface boring logs (if any).

**Contract Bond** – The approved form of security furnished by the Contractor and the Contractor's Surety as required by the Contract, that guarantees performance of all the Work required by the Contract and payment to anyone who provides supplies or labor for the performance of the Work.

**Contract Form (Agreement Form)** – The form provided by the Contracting Agency that requires the authorized signatures of the Contractor and the Contracting Agency to result in formal execution of the Contract.

**Contracting Agency** – Agency of Government that is responsible for the execution and administration of the Contract.

**Contractor** – The individual, partnership, firm, corporation, or joint venture, Contracting with the Contracting Agency to do prescribed Work.

**Contract Plans** – A publication addressing the Work required for an individual project.

At the time of the call for Bids, the Contract Plans may include, but are not limited to, the following: a vicinity map, a summary of quantities, structure notes, signing information, traffic control plans, and detailed drawings; all for a specific individual project. At the time of the Contract execution date, the Contract Plans include any Addenda.

**Contract Provisions** – A publication addressing the Work required for an individual project. At the time of the call for Bids, the Contract Provisions may include, for a specific individual project, the amendments to the Standard Specifications, the Special Provisions, a listing of the applicable *Standard Plans*, the prevailing minimum hourly wage rates, and an informational Proposal Form with the listing of Bid items. The proposed Contract Provisions may also include, for a specific individual project, the Required Contract Provisions Federal aid Construction Contracts, and various required certifications or declarations. At the time of the Contract execution date, the Contract Provisions include the proposed Contract Provisions and include any Addenda, a copy of the Contract Form, and a copy of the Proposal Form with the Contract prices and extensions.

**Proposal Form** – The form provided to Bidders by the Contracting Agency for submittal of a Proposal or Bid to the Contracting Agency for a specific project. The form includes the item number, estimated plan quantity, and item description of the Bid items along with blank spaces to be completed by the Bidder for the unit prices, extensions, the total Bid amount, signatures, date, acknowledgment of Addenda, and the Bidder's address. The required certifications and declarations are part of the form.

**Specifications** – Provisions and requirements for the prescribed Work.

**Subcontractor** – An individual, partnership, firm, corporation, or joint venture who is sublet part of the Contract by the Contractor.

**Surety** – A company that is bound with the Contractor to ensure performance of the Contract, payment of all obligations pertaining to the Work, and fulfillment of such other conditions as are specified in the Contract, Contract Bond, or otherwise required by law.

**Work** – The provision of all labor, materials, tools, equipment, and everything needed to successfully complete a project according to the Contract.

# GENERAL INFORMATION AND CONTRACT PROVISIONS

---

## GENERAL INFORMATION

**PROJECT TITLE:** Blanchard Quiet Zone Median Curb Construction, Project #ES20830-3, ES20830-3A.

These general provisions are hereby a part of the conditions agreed to by the Contractor upon Bid. Skagit County Public Works is guided by RCW 39.04, and utilizes the *2016 Standard Specifications for Road, Bridge, and Municipal Construction*.

**DESCRIPTION OF WORK:** This contract provides for the construction and installation of Dual-Faced Cement Concrete Traffic Curb as shown in the contract plans. The method and materials (including forms, bonding materials, epoxy coated steel dowel bars (for pinning) and any other related materials) shall be approved by the Project Engineer prior to beginning construction. Extruded or other slip-based methods are encouraged.

This work will be performed adjacent to, and within, Burlington Northern Santa Fe Railroad (BNSF) right-of-way. See the requirements outlined below, in the Upon Award of Contract section.

Upon beginning work, the contractor shall have 3 working days to complete construction.

**BID DUE DATE AND TIME:** Friday, December 8, 2017 at 3:30 p.m.

**ENGINEER'S ESTIMATE:** \$6,000.00 - \$8,000.00

**UPON AWARD OF CONTRACT:** After contract award, the Contractor will be required to sign an acknowledgement of and in agreement to comply with standard contract provisions required by BNSF when performing work within the railroad right-of-way. The contract will include standard provisions for railroad notification procedures, insurance requirements, safety requirements, and contact information in case of an emergency.

Portions of this project require work on and near the Burlington Northern Santa Fe (BNSF) tracks and right-of-way. The contractor shall schedule and conduct all work activities so as not to interfere with the movement of any trains nor create any hazard to BNSF's property, employees, and/or operations. When entering the right-of-way, the contractor shall abide by all rules and regulations of the BNSF relative to entering their right-of-way. At a minimum, the contractor shall have one person that has received BNSF safety training and is authorized by BNSF to enter their right-of-way. BNSF information can be found at [www.BNSFcontractor.com](http://www.BNSFcontractor.com)

The contractor shall coordinate with Skagit County to notify BNSF in writing at least 30 days before commencing work in the BNSF right-of-way. The contractor shall be aware that work in the proximity of the railway tracks is potentially hazardous where movement of trains and equipment can occur at any time and in any direction. The contractor shall develop and submit a safety plan that they will use to protect their employees, subcontractors, agents, or invitees from moving trains.

**NOTICE TO PROCEED:** Contractor shall not commence work until notice to proceed has been given by Skagit County; this occurs after the Contract has been executed by the Board of Skagit County Commissioners.

**SCHEDULE:** 3 working days. Work can begin upon Notice to Proceed, issued by the Project Engineer.

**ADDENDA:** If Skagit County issues addenda to these instructions, bidders must acknowledge receipt of all addenda on the bid proposal. It is the Bidder's responsibility to ensure that he/she has received all addenda, although Skagit County will make reasonable effort to provide addenda to all plan holders. Addenda will be forwarded to Contractors on the Plan Holder list via email, and will be posted online at [www.skagitcounty.net/rfp](http://www.skagitcounty.net/rfp). Failure to sign the acknowledgement of addenda on the revised proposal packet may result in rejection of the bid.

**All addenda will be posted on-line for this work by 3:30 p.m. on Wednesday, December 6, 2017.** All addenda shall become part of the bid package. If further addenda are required to be issued, after Wednesday, December 6, 2017, the bid opening will be postponed. Contractors on the Plan Holder list will be notified of postponement via phone and email. Postponement notice will also be posted online at [www.skagitcounty.net/rfp](http://www.skagitcounty.net/rfp).

**MANDATORY BIDDER RESPONSIBILITY CRITERIA:** Before award, the bidder must meet the following bidder responsibility criteria to be considered a responsible bidder. The bidder may be required by Skagit County to submit documentation demonstrating compliance with the criteria.

The bidder must:

1. Have a current certificate of registration as a contractor in compliance with RCW 18.27, which must have been in effect at the time of bid submittal;
2. Have a current Washington Unified Business Identifier (UBI) number;
3. Have Industrial Insurance (workers' compensation) coverage for the bidder's employees working in Washington, as required in Title 51 RCW;
4. Have a Washington Employment Security Department number (ESD), as required in Title 50 RCW, **(and, if lowest responsive and responsible bidder, provide documentation in the form of a letter or statement from ESD within 24 hours of submitting bid);**
5. Have a Washington Department of Revenue state excise tax registration number, as required in Title 82 RCW;
6. Not be disqualified from bidding on any public works contract under RCW 39.06.010 or RCW 39.12.065(3) and;
7. Not be excluded or suspended from bidding on any public works contract under federal laws.

**INTERPRETATION OF BID AND PURCHASE DOCUMENTS:** Skagit County will not provide binding oral interpretations to Bidders as the meaning of bid or contract documents; oral communication is not binding upon Skagit County.

**TITLE IV:** Skagit County ensures full compliance with Title VI of the Civil Rights Act of 1964 by prohibiting discrimination against any person on the basis of race, color, national origin, or sex in the provision of benefits and services resulting from the federally assisted programs and

activities. For questions regarding Skagit County's Title VI Program, you may contact the Skagit County Public Works Department's Title VI Liaison, Keith Elefson, at (360) 416-1456.

**EXAMINATION OF BID AND CONTRACT DOCUMENTS, SITE, AND SITE CONDITIONS:**

Bid submission constitutes acknowledgement, upon which Skagit County may rely, that Bidder thoroughly examined and is familiar with the Contract Provisions and Specifications documents, familiar with all applicable worksites, reviewed and inspected all applicable laws, statutes, regulations, ordinances and resolutions dealing with or related to the work and services to be provided, and received, and considered all addenda. Failure or neglect of Bidder to examine such documents, work site(s), statutes, regulations, ordinances, or resolutions shall in no way relieve the Bidder from any obligations with respect to the Bidder's offer or to the contract. No claim for additional compensation will be allowed, which is based upon a lack of knowledge of any contract documents, work site(s), specifications, delivery requirements, statutes, regulations, ordinances or resolutions. A signed contract furnished to the successful Contractor results in a binding contract without further action by either party.

**BID PROCEDURES AND CONDITIONS**

**PROPOSAL FORMS:** At the request of a bidder, the Contracting Agency will provide a proposal form for any project on which the bidder is eligible to bid.

The proposal form will identify the project, list estimated quantities, units of measurement, the items of work, and the materials to be furnished at the unit bid prices. The bidder shall complete spaces on the proposal form that call for information such as: unit prices; extensions; total bid amount; signatures; date; retail sales taxes; the bidder's name, address, telephone number, and signature.

**PREPARATION OF PROPOSAL:** The Contracting Agency will accept only those Proposals properly executed on forms it provides.

All prices shall be in legible figures (not words) written in ink or typed. The Proposal shall include:

1. A unit price for each item (omitting digits more than four (4) places to the right of the decimal point)
2. An extension for each unit price (omitting digits more than two (2) places to the right of the decimal point)
3. The total Contract price (the sum of all extensions)

**BID PRICE:** The bidder shall submit the completed Bid Proposal as part of the bid. The bid shall include everything necessary for the prosecution and completion of the Contract including, but not limited to, furnishing all material, labor, equipment, and Subcontractors, and other facilities and all management, superintendent's labor and service as outlined in the Provisions, except as may be provided otherwise in the Contract documents. In the event of a discrepancy between the unit price and the total price, the unit price will govern and Skagit County will correct total price accordingly.

**SIGNATURES:** Bids shall be signed by one of the legally authorized officers of said corporation. If awarded the contract, the Contract shall also be so executed. If a Bid Proposal



or Contract is signed by an agent, the agent shall provide satisfactory evidence of authority to sign as legal representative of Bidder, upon request of Skagit County. An authorized partner of a co-partnership may sign the contract, subject to the approval of the attorney, who may at his discretion, require each and every member of the co-partnership to sign the contract.

**DELIVERY OF PROPOSAL:** Sealed bids will be received by the Board of Skagit County Commissioners. Bids must be received no later than Friday, December 6, 2017 at 3:30 p.m. according to the SKAGIT COUNTY COMMISSIONERS' Reception Desk clock. All bid envelopes must be plainly marked on the outside, "Sealed Bid: Maintenance of Restoration Projects".

Hand-deliver or Mail to:  
Skagit County Commissioners  
1800 Continental Place, Suite 100  
Mount Vernon, WA 98273

It is the Contractor's responsibility to allow enough time for delivery to occur before the designated time. Quotations delivered to locations other than as indicated above or received after the designated time will not be accepted. Incomplete proposals cannot be considered. Oral, telephonic, telegraphic, electronic, or faxed proposals will not be accepted.

Skagit County reserves the right to reject any or all bids, waive informalities, and make the award in the best interest of Skagit County. Quotation results and questions pertaining to this project can be obtained by calling Emily Derenne, Restoration Habitat Specialist, at (360) 416-1449.

Bids remain confidential and no information about bids is released until the public information of the bids is otherwise available.

**WITHDRAWAL OR REVISION OF PROPOSAL:** After submitting a Bid Proposal to the Contracting Agency, the Bidder may withdraw or revise if:

1. The Bidder submits a written request signed by an authorized person, and
2. The Contracting Agency receives the request before the time for opening Bids.

The original Bid Proposal may be revised and resubmitted as the official Bid Proposal, if the Contracting Agency receives it before the time for opening Bids.

**BID BOND/GUARANTY:** No bid will be considered unless accompanied by a surety company bid bond, Cashier's or certified check payable to the order of Skagit County for a sum not less than five percent (5%) of the estimated bid amount. Should the successful bidder fail to enter into such contract, the bid bond will be forfeited to Skagit County.

**NON-COLLUSION:** Submittal and signature of the non-collusion certificate confirms the bid is genuine and not a sham or collusive, and not made in the interest of any person not named, and that the Contractor has not induced or solicited others to submit a sham offer, or to refrain from proposing.

**CONSIDERATION OF BIDS:** After opening and reading proposals, the Contracting Agency will check them for correctness of extensions of the prices per unit and the total price. If a discrepancy exists between the price per unit and the extended amount of any bid item, the

price per unit will control. The total of extensions, corrected where necessary, will be used by the Contracting Agency for Award purposes and to fix the amount of the Contract Bond.

The right is reserved by the Contracting Agency to waive informalities in the bidding, accept a Proposal of the lowest responsible Bidder, reject any or all Bids, republish the call for Bids, revise or cancel the Work, or require the Work to be done in another way, if the best interest of the Contracting Agency is served.

A Bidder who wishes to claim error after the Bids have been opened and read as required by RCW 47.28.090 shall promptly notify the Contracting Agency that an error occurred. The Bidder shall submit a notarized affidavit or declaration under penalty of perjury signed by the Bidder and accompanied by the work sheets used in the preparation of the Bid, requesting relief from the responsibilities of Award. The affidavit or declaration shall describe the specific error(s) and certify that the work sheets are the ones used in preparing the Bid.

The affidavit or declaration shall be submitted no later than 4:30 p.m. on the first business day after Bid opening or the claim will not be considered. The Contracting Agency will review the affidavit or declaration and the certified work sheets to determine the validity of the claimed error and if the error is of the kind for which the law allows relief from forfeiture of the Bid deposit. If the Contracting Agency concurs in the claim of error and determines that the error is of the kind which allows relief from forfeiture, the Bidder will be relieved of responsibility and the Bid deposit of the Bidder will be returned. If the Contracting Agency does not concur in the error or determines that the error is not the kind for which the law allows relief, the Contracting Agency may Award the Contract and if the Bidder refuses to execute the Contract, the Bidder's Bid deposit shall be forfeited as required by RCW 47.28.100. RCW 39.04.107 applies, thereafter.

**NON-RESPONSIVE BID:** Any bid that does not comply with these instructions, is not signed, supplements or deviates from the specifications herein, or is incomplete, may be declared non-responsive by Skagit County and not further considered.

**TIED BIDS:** After opening Bids, if two or more lowest responsive Bid totals are exactly equal, then the tie breaker will be determined by drawing as described in Section 1-03.1(1) of the 2016 WSDOT Standard Specifications. Two or more slips of paper will be marked as follows: one marked "Winner" and the other(s) marked "unsuccessful". The slips will be folded to make the marking unseen. The slips will be placed inside a box. One authorized representative of each Bidder shall draw a slip from the box. Bidders shall draw in alphabetical order by the name of the firm as registered with the Washington State Department of Licensing. The slips shall be unfolded and the firm with the slip marked "Winner" will be determined to be the successful Bidder and eligible for Award of Contract. Only those Bidders who submitted a Bid total that is exactly equal to the lowest responsive and responsible Bids are eligible to draw.

**IRREGULAR PROPOSALS:**

1. A Proposal will be considered irregular and *will* be rejected if:
  - a) The Bidder is not prequalified
  - b) The authorized Proposal form furnished by the Contracting Agency is not used or is altered
  - c) The completed Proposal form contains any unauthorized additions, deletions, alternate Bids, or conditions
  - d) The Bidder adds provisions reserving the right to reject or accept the Award or enter into the Contract
  - e) A price per unit cannot be determined from the Bid Proposal
  - f) The Proposal form is not properly executed

- g) The Bid Proposal does not constitute a definite and unqualified offer to meet the material terms of the Bid invitation.
- 2. A proposal may be considered irregular and *may* be rejected if:
  - a) The Proposal does not include a unit price for every Bid item
  - b) Any of the unit prices are excessively unbalanced (either above or below the amount of a reasonable Bid) to the potential detriment of the Contracting Agency
  - c) Receipt of Addenda (if applicable) is not acknowledged
  - d) A member of a joint venture or partnership and the joint venture or partnership submit Proposals for the same project (in such an instance, both Bids may be rejected)
  - e) Proposal form entries are not made in ink or typed.

**DISQUALIFICATION OF BIDDERS:** As stated in Section 1-02.14 of the 2016 WSDOT Standard Specifications, a bidder may be deemed not responsible and their proposal rejected if:

- 1. the Bidder does not meet the mandatory bidder responsibility criteria, described above and in RCW 39.04.350(1), as amended; or
- 2. more than one proposal is submitted for the same project from a Bidder under the same or different names; or
- 3. evidence of collusion exists with any other Bidder or potential Bidder. Participants in collusion will be restricted from submitting further bids; or
- 4. the Bidder, in the opinion of the Contracting Agency, is not qualified for the work or to the full extent of the bid, or to the extent that the bid exceeds the authorized prequalification amount as may have been determined by a prequalification of the Bidder, or
- 5. an unsatisfactory performance record exists based on past or current Contracting Agency work or for work done for others, as judged from the standpoint of conduct of work; workmanship; progress; affirmative action; equal employment opportunity practices; termination for cause; or Disadvantaged Business Enterprise, Minority Business Enterprise, or Women's Business Enterprise utilization; or
- 6. there is uncompleted work (Contracting Agency or otherwise), which in the opinion of the Contracting Agency might hinder or prevent the prompt completion of the Work bid upon; or
- 7. the Bidder failed to settle bills for labor or materials on past or current contracts, unless there are extenuating circumstances acceptable to the Contracting Agency; or
- 8. the Bidder has failed to complete a written public contract or has been convicted of a crime arising from a previous public contract, unless there are extenuating circumstances acceptable to the Contracting Agency; or
- 9. the Bidder is unable, financially or otherwise, to perform the work, in the opinion of the Contracting Agency; or
- 10. a Bidder is not authorized to do business in the state of Washington; or
- 11. there are any other reasons deemed proper by the Contracting Agency.

**PROTESTS:** Protests will be in accordance with all RCWs, as applicable.

## **AWARD OF CONTRACT**

**CONDITION OF AWARD:** It is the intent of Skagit County to award a contract to the lowest responsive and responsible bidder. The Board of Skagit County Commissioners reserves the right to reject any or all bids for cause, and to waive minor irregularities in the bidding.

**ACCEPTANCE OF AWARD:** If awarded, the Contractor is deemed to have agreed to all Addenda, Bid Instruction to bidders, General and Contract Provisions, Scope of Work, Specifications, Contract, and all other related documents.

**COORDINATION OF DOCUMENTS:** Any inconsistency in the parts of the Contract shall be resolved by following this order of precedence (e.g., 1 presiding over 2, 3, 4, 5, 6, and 7; 2 presiding over 3, 4, 5, 6, and 7; and so forth):

1. Addenda,
2. Proposal Form,
3. Special Provisions,
4. Contract Plans,
5. Amendments to the Standard Specifications,
6. Standard Specifications, and
7. Standard Plans.

On the Contract Plans, Working Drawings, and Standard Plans, figured dimensions shall take precedence over scaled dimensions.

This order of precedence shall not apply when Work is required by one part of the Contract but omitted from another part or parts of the Contract. The Work required in one part must be furnished even if not mentioned in other parts of the Contract.

Whenever reference is made in these Specifications or the Special Provisions to codes, rules, specifications, and standards, the reference shall be construed to mean the code, rule, specification, or standard that is in effect on the Bid advertisement date, unless otherwise stated or as required by law.

If any part of the Contract requires Work that does not include a description for how the Work is to be performed, the Work shall be performed in accordance with standard trade practice(s). For purposes of the Contract, a standard trade practice is one having such regularity of observance in the trade as to justify an expectation that it will be observed by the Contractor in doing the Work.

In case of any ambiguity or dispute over interpreting the Contract, the Engineer's decision will be final as provided in 2016 WSDOT Standard Specifications Section 1-05.1.

## **CONTRACT**

**EXECUTION OF CONTRACT:** Successful bidder is allowed a maximum of ten (10) calendar days after the award date to return the signed contract, contract bond, all required insurance certifications, and any other required documentation as specified in this document.

**CONTRACT DOCUMENTS:** The Addenda, Bid Proposal, General and Contract Provisions and Specifications, and Contract, shall be a part of and constitute the Contract entered into by Skagit County and successful Bidder. In the event there is discrepancy between any of the foregoing contract documents, the above order of documents governs so that the former prevails over the latter.

**CONTRACT BOND:** The successful Bidder shall provide an executed contract bond for the full contract amount. This contract bond shall:

1. Be on a Contracting Agency-furnished form;
2. Be signed by an approved Surety (or Sureties) that:
  - a. Is registered with the Washington State Insurance Commissioner, and
  - b. Appears on the current Authorized Insurance List in the State of Washington published by the Office of the Insurance Commissioner,
3. Be conditioned upon the faithful performance of the contract by the Contractor within the prescribed time;
4. Guarantee that the Surety shall indemnify, defend, and protect the Contracting Agency against any claim of direct or indirect loss resulting from the failure:
  - a. Of the Contractor (or any of the employees, subcontractors, or lower tier subcontractors of the Contractor) to faithfully perform the contract, or
  - b. Of the Contractor (or the subcontractors or lower tier subcontractors of the Contractor) to pay all laborers, mechanics, subcontractors, lower tier subcontractors, material or any other person who provides supplies or provisions for carrying out the work;

The Contracting Agency may require Sureties or Surety companies on the Contract Bond to appear and qualify themselves. Whenever the Contracting Agency deems the Surety or Sureties to be inadequate, it may, upon written demand, require the Contractor to furnish additional Surety to cover any remaining work. Until the added Surety is furnished, payments on the Contract will stop.

**RETAINAGE:** RCW 60.28.011 states that public improvement contracts shall provide, and public bodies shall reserve, contract retainage not to exceed five percent (5%) of the moneys earned by the contractor as a trust fund for the protection and payment of:

1. The claims of any person arising under the Contract; and
  - a) The State with respect to taxes imposed pursuant to Title 82 RCW, which may be due from such Contractor.

At the option of the Contractor, the monies reserved shall be:

1. Retained in a custodial fund by Skagit County (non-interest bearing)
2. Deposited by Skagit County in an escrow (interest bearing) account in a bank or savings and loan institution (interest on monies so retained will be paid to the Contractor). Deposits are to be made in the name of the Contracting Agency and are not allowed to be withdrawn without the Contracting Agency's written authorization. The Contracting Agency will issue a check representing the sum of the monies reserved, payable to the bank or trust company. Such check shall be converted into bonds and securities chosen by the Contractor as the interest accrues.

At the time the Contract is executed the Contractor shall designate the option desired. The Contractor in choosing option (2) agrees to assume full responsibility to pay all costs that may

accrue from escrow services, brokerage charges for both and further agrees to assume all risks in connection with the investment of the retained percentages in securities. The Contracting Agency may also, at its option, accept a retainage bond in lieu of retainage.

The retained percentage will be released sixty (60) days following the Completion Date provided all of the following conditions have been satisfied:

1. On Contracts totaling more than \$35,000, a release has been obtained from the Washington State Department of Revenue.
2. The Contractor and all Subcontractor(s) files with the Department of Labor and Industries an "Affidavit of Wages Paid" and the approved document is received by Skagit County.
3. A certificate of Payment of Contributions Penalties and Interest on Public Works Contract is received from the Washington State Employment Security Department.
4. All claims, as provided by law, filed against the retainage have been resolved. In the event claims are filed and provided the conditions of 1, 2, 3, and 4 are met, the Contractor will be paid such retained percentage less an amount sufficient to pay any such claims together with a sum determined by the Contracting Agency sufficient to pay the cost of foreclosing on claims and to cover attorney's fees.
5. The Contractor has obtained a certificate showing that all contract-related taxes have been paid from the Washington State Department of Revenue.

**INSURANCE:** Contractor shall comply with the following conditions and procure and keep in force during the term of this Agreement, at Contractor's own cost and expense, the following policies of insurance with companies authorized to do business in the State of Washington, which are rated at least "A" or better and with a numerical rating of no less than seven (7), by A.M. Best Company and which are acceptable to the County.

1. Commercial General Liability Insurance on an occurrence basis in an amount not less than \$1,000,000 per occurrence and at least \$1,000,000 in the annual aggregate, including but not limited to: premises/operations (including off-site operations), blanket contractual liability and broad form property damage.
2. Business Automobile Liability Insurance in an amount not less than \$1,000,000 per occurrence, extending to any automobile.
3. Workers' Compensation Insurance as required by Washington law and Employer's Liability Insurance (Stop Gap) with limits not less than \$1,000,000 per occurrence. If the County authorizes sublet work, the Contractor shall require each Subcontractor to provide Workers' Compensation Insurance for its employees, unless the Contractor covers such employees.

The above liability policies shall contain a provision that the policy shall not be canceled or materially changed without thirty (30) days prior written notice to the County. No cancellation provision in any insurance policy shall be construed in derogation of the continuous duty of the Contractor to furnish the required insurance during the term of this Agreement.

Upon written request by the County, the insurer or his/her agent will furnish, prior to or during any Work being performed, a copy of any policy cited above, certified to be a true and complete copy of the original.

**ADDITIONAL INSURED:** Prior to the Contractor performing any Work, Contractor shall provide the County with a Certificate of Insurance acceptable to the County Attorney evidencing the above-required insurance and naming Skagit County, its officers, employees and agents as

Additional Insureds on the Commercial General Liability Insurance policy and the Business Automobile Liability Insurance policy with respect to the operations performed and services provided under this Agreement and that such insurance shall apply as primary insurance on behalf of such Additional Insureds. Skagit County shall be named as an Additional Insured by endorsement using ISO Form CG 2010 or equivalent. Receipt by the County of any certificate showing less coverage than required is not a waiver of the Contractor's obligations to fulfill the requirement.

The insurance policies required in this Contract are to contain and be endorsed to contain the following provisions:

With respect to all Liability Policies:

Skagit County its officers, officials, employees, and agents and volunteers are named as additional insured's as respects liability arising out of activities performed by or on behalf of the Contractor in connection with this Contract.

The Contractor's insurance coverage shall be primary insurance as respects Skagit County, its officers, officials, employees, agents, volunteers and consultants. Any insurance and/or self-insurance maintained by Skagit County, its officers, officials, employees, agents and consultants shall not contribute with the Contractor's insurance or benefit the Contractor in any way.

An additional insureds endorsement template can be provided by Skagit County, upon request.

**PUBLIC WORKS PROJECT – PREVAILING WAGE:** If awarded the project, the Contractor and each Subcontractor shall complete or have on file with the County a current "Statement of Intent to Pay Prevailing Wages" before payment will be made for work performed. An "Affidavit of Wages Paid" shall be required at the end of the project, before final payment is authorized. These forms are available from Washington State Department of Labor & Industries and can be filed electronically at <http://www.lni.wa.gov/TradesLicensing/PrevWage>.

The State of Washington prevailing wage rates applicable for this public works project, which is located in Skagit County, may be found at the following website address of the Department of Labor and Industries: <https://fortress.wa.gov/lni/wagelookup/prvWagelookup.aspx>. Based on the bid submittal deadline for this project, the applicable effective date for prevailing wages for this project is Wednesday, June 14, 2017. A copy of the applicable prevailing wage rates are also available for viewing at the office of the Owner, located at 1800 Continental Place, Mount Vernon, WA 98273. Upon request, the Owner will mail a hard copy of the applicable prevailing wages for this project.

Any materials purchased will be used in public work type projects as defined in RCW 39.12, and therefore, subject to state prevailing wage rates as set forth by the Washington Department of Labor and Industries. Bidders are advised to consider this charge when computing bids.

**LICENSES AND PERMITS:** Contractor shall procure all permits and licenses, pay all charges, fees and taxes, and give all notices necessary and incidental to the due and lawful prosecution of the work. Contractors awarded a County Contract are responsible for compliance with Washington State Business License regulations. Contractors must also carry appropriate and valid Washington State Department of Agricultural herbicide licenses for aquatic and terrestrial environments.

**SUBCONTRACTING:** No portion of the contract may be assigned or subcontracted to any other individual, firm, or entity without the express and prior written approval of the County. As stated in Section 1-08.1 of the 2016 WSDOT Standard Specifications, the Contractor shall verify that every first tier Subcontractor meets the responsibility criteria stated below at the time of subcontract execution. The Contractor shall include these responsibility criteria in every subcontract, and require every Subcontractor to:

1. Possess any electrical contractor license required by RCW 19.28 or elevator contractor license required by RCW 70.87, if applicable;
2. Have a certificate of registration in compliance with chapter RCW 18.27;
3. Have a current State unified business identifier number;
4. If applicable, have:
  - a. Industrial insurance coverage for the bidder's employees working in Washington (Title 51 RCW);
  - b. An employment security department number (Title 50 RCW);
  - c. A State excise tax registration number (Title 82 RCW);
5. Not be disqualified from bidding on any public works contract under RCW 39.06.010 or RCW 39.12.065(3).
6. Verify these responsibility criteria for every lower tier subcontractor at the time of subcontract execution; and,
7. Include these responsibility criteria in every lower tier subcontract.

**CHANGES/AMENDMENTS:** Skagit County reserves the right to add or delete work, items, agencies, or locations from this contract, subject to appropriate adjustments to the Contract price. Added items, agencies, or locations will be related to those on contract, and additions or deletions will be by mutual agreement, with prices consistent with the original bid price margins, and evidenced by an amendment to the Contract. The execution of an amendment shall constitute a waiver of Claims by the Contractor arising out of the Work to be performed or deleted pursuant to the amendment, except as specifically described in the amendment. General reservations of rights will be deemed waived and void.

**WARRANTY OF WORK:** In summary, Contractor hereby warrants that all of the work, materials or equipment furnished under this Contract will fully meet all requirements for quality of workmanship, materials, strength and any and all other requirements of the specifications. The Contractor shall remedy any defects in the work and pay for any damage to other work resulting there from, which shall appear within a period of one year from the date of final acceptance of the work unless a longer period is specified. Skagit County will give notice of observed defects with reasonable promptness. The guarantee period shall be suspended from the time a significant defect is first documented by Skagit County until the work or equipment is repaired or replaced by the Contractor and accepted by Skagit County. In the event that fewer than 90 days remain in the guarantee period after acceptance of such repair or replacement (after deducting the period of suspension above), the guarantee period shall be extended to allow for at least 90 days guarantee of the work from the date of acceptance of such repair or replacement.

**MATERIAL APPROVAL:** All materials are in accordance with Specifications. Any substitutions of products are subject to Skagit County's prior approval, and, if rejected, are held subject to the Contractor's risk and expense.

**EQUAL OPPORTUNITY AND NONDISCRIMINATION:** Hiring or employment made possible or resulting from this Contract, there shall be no unlawful discrimination against any employee or applicant for employment because of sex, age, race, color, creed, national origin, marital



status or the presence of any sensory, mental, or physical handicap, unless based upon a bona fide occupational qualification. This requirement shall apply to but not be limited to the following: employment, advertising, layoff or termination, rates of pay or other forms of compensation, and selection for training, including apprenticeship. No person shall be denied or subjected to discrimination in receipt of the benefit of any services or activities made possible by or resulting from this contract on the grounds of sex, race, color, creed, national origin, age, (except minimum age and retirement provisions), marital status, or in the presence of any sensory, mental, or physical handicap.

**FAILURE TO EXECUTE CONTRACT:** Upon failure to return the performance and payment bonds, insurance certifications, and any other required documentation as specified in this document with the signed contract, as required, Skagit County may then award the contract to the second lowest responsive and responsible Bidder, or reject all remaining bids.

**RETURN OF BID BOND/GUARANTY:** Proposal bonds and deposits will be held until the Contract has been properly executed pursuant to RCW 36.32.250. When the Contract has been properly executed, all remaining bonds or deposits, except those subject to forfeiture, will be returned.

## **LEGAL RELATIONS AND RESPONSIBILITIES TO THE PUBLIC**

**COMPLIANCE WITH LAWS:** Contractor shall comply with all applicable federal, state, tribal and local laws, rules, and regulations affecting its performance and hold Skagit County harmless against any claims arising from the violation thereof. No extension of time or additional payment will be made for loss of time or disruption of work caused by any actions against the Contractor for any of the above reasons.

**APPLICABLE LAW AND FORUM:** Except as specifically provided, this Contract shall be governed by and construed according to the laws of the State of Washington. Any suit arising here from shall be brought in Skagit County Superior Court, which forum shall have sole and exclusive jurisdiction and venue.

**APPLICATION OF SALES TAX:** The work on this contract is to be performed upon lands whose ownership obligates the Contractor to pay State sales tax. Department of Revenue Rule 171 applies to this project. This work is not exempt from Sales Tax. The contractor shall include appropriate sales tax as shown on the Bid Proposal. The Contracting Agency will not adjust its payment if the Contractor bases a bid on a misunderstood tax liability.

**DEFENSE & INDEMNITY AGREEMENT:** The Contractor agrees to defend, indemnify and save harmless the County, its appointed and elective officers and employees, from and against all loss or expense, including but not limited to judgments, settlements, attorney's fees and costs by reason of any and all claims and demands upon the County, its elected or appointed officials or employees for damages because of personal or bodily injury, including death at any time resulting therefrom, sustained by any person or persons and on account of damage to property including loss of use thereof, whether such injury to persons or damage to property is due to the negligence of the Contractor, its subcontractors, its elected officers, employees or their agents, except only such injury or damage as shall have been occasioned by the sole negligence of the County, its appointed or elected officials or employees. It is further provided that no liability shall attach to the County by reason of entering into this contract, except as expressly provided herein.

**HOLD HARMLESS:** The Contractor shall hold Skagit County and its officers, agents and employees harmless from all costs, claims or liabilities of any nature including attorneys; fees, costs and expenses for or on account of injuries or damages sustained by any persons or property resulting from the negligent activities or omissions of the Contractor, its agents or employees pursuant to the Contract, or on account of any unpaid wages or other remuneration for services; and if a suit as described above be filed, the Contractor shall appear and defend the same at its own cost and expense, and if judgment be rendered or settlement made requiring payment by Skagit County, the Contractor shall pay the same.

**SAFETY MEASURES:** All work under this Contract shall be performed in a safe manner. Contractor and all subcontractors shall observe all rules and regulations of the Washington State Department of Labor and Industries, rules and regulations of OSHA, WISHA, or any other jurisdiction, and all other applicable safety standards. Contractor shall be solely and completely responsible for conditions of the job site, including safety of all persons and property during performance of the work. This requirement shall apply continuously and not be limited to normal working hours.

Contractor shall exercise every precaution at all times for the prevention of accidents and the protection of persons (including employees) and property. All exposed moving parts of equipment capable of inflicting injury by accidental contact shall be protected with sturdy removable guards, in accordance with applicable safety regulations.

**MUTUAL RESPONSIBILITY OF CONTRACTOR:** If, through acts of neglect on the part of the Contractor, any other Contractor or any subcontractor shall suffer loss or damage on the work, the Contractor agrees to settle with such other Contractor(s) or subcontractor(s) by agreement or arbitration if such other Contractor(s) or subcontractor(s) will so settle. If such other Contractor(s) or subcontractor(s) shall assert any claim against Skagit County account of any damage alleged to have been sustained, Skagit County shall notify Contractor, who shall indemnify and save harmless Skagit County against any such claim.

**TERMINATION FOR BREACH AND/OR DEFAULT:** Skagit County shall be entitled by written notice, to cancel and/or terminate this contract in its entirety or in part, for breach and/or for default of any of the terms and to have all other rights against the Contractor by reason of the Contractors breach, as provided by law.

*Breach: A breach of a term or condition of the Contract shall mean any one or more of the following: (1) Contractor fails to perform the services by the date required or by a later date as may be agreed to in a written amendment to the contract; (2) Contractor breaches any warranty or fails to perform or comply with any term or agreement in the contract; (3) Contractor makes any general assignment for the benefit of creditors; (4) in Skagit County's sole opinion, Contractor becomes insolvent or in an unsound financial condition so as to endanger performance; (5) Contractor becomes the subject of any proceeding under any law relating to bankruptcy, insolvency, reorganization, or relief from creditors and/or debtors; (6) any receiver, trustee, or similar official is appointed for Contractor or any of the Contractor's property; (7) Contractor is determined to be in violation of federal, state or local laws or regulations and that such determination, in Skagit County's sole opinion, renders the Contractor unable to perform any aspect of the contract.*

*Default: A Contractor may be declared in default for failing to perform a contractual requirement or for a material breach of any term or condition.*

Opportunity to Cure Default: In the event that Contractor fails to perform a contractual requirement or materially breaches any term or condition, Skagit County may issue a written or oral notice of default and provide a period of time in which Contractor shall have the opportunity to cure. Time allowed for cure shall not diminish or eliminate Contractor's liability for liquidated or other damages. Skagit County is not required to allow the Contractor to cure defects if the opportunity for cure is not feasible as determined solely by Skagit County. Skagit County may terminate the Contract for nonperformance, breach, or default without allowing the opportunity to cure by the Contractor.

Remedies for Cure of Default: In summary, if the nonperformance, breach or default remains after Contractor has been provided the opportunity to cure, Skagit County may do one or more of the following: (1) exercise any remedy provided by law; (2) terminate this Contract and any related contracts or portions thereof; (3) impose liquidated damages; (4) suspend Contractor from receiving future invitations to bid. Skagit County may procure the articles or services from other sources and hold the Bidder responsible for any excess and expense occasioned thereby, including delay in time, whether foreseeable or unforeseeable.

**TERMINATION FOR PUBLIC CONVENIENCE:** The County may terminate the contract in whole or in part whenever the County determines, in its sole discretion that such termination is in the best interests of the County. Whenever the contract is terminated in accordance with this paragraph, the Contractor shall be entitled to payment for actual work performed at unit contract prices for completed items of work. An equitable adjustment in the contract price for partially completed items of work will be made, but such adjustment shall not include provision for loss of anticipated profit on deleted or uncompleted work. Termination of this contract by the County at any time during the term, whether for default or convenience, shall not constitute a breach of contract by the County. If sufficient funds are not appropriated or allocated for payment under this contract for any future fiscal period, the County will not be obligated to make payments for services or amounts incurred after the end of the current fiscal period. No penalty or expense shall accrue to the County in the event this provision applies.

**CLAIMS AND DISPUTE RESOLUTION:** A Claim is a demand or assertion by one of the parties seeking, as a matter of right, adjustment of Contract terms, payment of money, extension of time or other relief with respect to the terms of the Contract. A Claim may also include other disputes and matters in question between Skagit County and Contractor arising out of or related to the Contract. Claims must be made in writing. The responsibility to substantiate Claims shall rest with the party making the Claim. A notice of a potential or future Claim does not constitute a Claim. Any Claims of the Contractor against Skagit County for damages, additional payment for any reason, or extension of time, whether under the Contract or otherwise, must be made in strict accordance with the applicable provisions of the Contract. No act, omissions, or knowledge, actual or constructive, of Skagit County shall in any way be deemed a waiver of the requirement for timely written notice and a timely written Claim unless Skagit County provides Contractor with an explicit, unequivocal written waiver.

All claims must be addressed to: Skagit County Engineer, 1800 Continental Place, Mount Vernon, WA 98273.

Contractor shall submit in writing to Skagit County all Claims, within seven (7) days of the event giving rise to the Claim. Written Claim must specify the conditions and requested relief. Skagit County shall consider such Claim and shall meet with the Contractor to confer and attempt to resolve the Claim.

Contractor shall diligently carry on the Work and maintain the Contractor's Construction Schedule during any dispute resolution proceedings, unless otherwise agreed by it and Skagit County in writing.

Mediation: If the Claim is not resolved in the process provided immediately above, neither the Contractor nor any Subcontractor or Supplier of any tier may bring a claim against Skagit County in litigation unless the Claim is first subject to nonbonding mediation before a single mediator under the Voluntary Construction Mediation Rules of the American Arbitration Association. This requirement cannot be waived except by an explicit written waiver signed by Skagit County and Contractor.

Litigation: Contractor may bring no litigation on Claims unless such Claims have been properly raised and considered as provided above. All unresolved Claims of Contractor shall be solved and released unless Contractor complies with the time limits above, and litigation is served and filed within the earlier of (a) 120 days after the day of Substantial Completion designed in writing by Skagit County (provided that a mediation session has occurred as provided above); or (b) 60 days after Final Acceptance. This requirement cannot be waived except by an explicit written waiver signed by Skagit County.

## **PAYMENT**

**INVOICES:** The Contractor shall be paid, upon submission of a proper invoice for payment request, the prices stipulated in the Contract for services performed (less deductions, if any), in accordance with all payment and retainage instructions herein. All accounts are paid according to RCW 39.76. Submitted Payment Requests must contain the following minimum information:

- Contract number;
- Item number, quantity and description as appropriate;
- Unit and extended prices.
- Approved Intent of Wages Paid with Department of Labor and Industries

Mail Payment Requests to:  
Skagit County Public Works  
ATTN: Forrest Jones  
1800 Continental Place  
Mount Vernon, WA 98273-5625

Payment will be made to the Contractor upon completion of all work and after final inspection and acceptance of the work by the Owner's Representative.

# SPECIFICATIONS

---

**SCOPE OF WORK:**

Skagit County is seeking the services of a contractor to provide construction and installation of dual-faced concrete curb in conformance with the contract plans.

Work shall take place within Skagit County at three (3) sites.

Site Locations:

<b>Road &amp; Milepost</b>	<b>Crossing No.</b>
Legg Rd, MP 0.077	084791W
Legg Rd, MP 0.537	084789V
Colony Rd, MP 0.683	084787G

**ANTICIPATED SERVICES:**

Anticipated services may cover, but not be limited to, work related to curb construction, and installation, as shown in the contract plans.

It is anticipated that 100% or more of the work will be performed during the Contractor's normal business hours.

**GENERAL NATURE OF THE WORK:**

The contractor shall, in conformance with the contract plans, construct and install dual-faced cement concrete curb on an existing BST surface. This work will occur within Skagit County, on public roads near and within Burlington Northern Santa Fe Railroad (BNSF) right-of-way. It is the contractor's responsibility to comply with the conditions of this contract with regard to working within BNSF right-of-way. Skagit County will provide the necessary workzone traffic control to perform the work. However, it will be the responsibility of the Contractor to obtain any necessary permits or permissions to enter upon private property as a condition of performing this contracted work. The contractor shall coordinate with Skagit County to stage and schedule the work. No work shall begin without prior approval of the Project Engineer.

# SPECIAL PROVISIONS

---

The following Special Provisions are made a part of this contract and supersede any conflicting provisions of the 2016 Standard Specifications for Road, Bridge and Municipal Construction, and the foregoing Amendments to the Standard Specifications.

(\*\*\*\*\*)

## **8-04.3(1) Cement Concrete Curbs, Gutters, and Spillways**

The first paragraph of Section 8-04.3(1) is revised to read:

Cement concrete curb, curb and gutter, gutter, and spillway shall be constructed with air entrained concrete Class 4000 conforming to the requirement of Section 6-02 except at driveway entrances. Cement concrete curb or curb and gutter along the full width of a driveway entrance shall be constructed with air entrained concrete Class 4000 conforming to the requirements of Section 6-02.

(\*\*\*\*\*)

## **8-04.3(1)A Extruded Cement Concrete Curb**

The content of this section is revised to read:

Extruded cement concrete curb shall be placed, shaped, and compacted true to line and grade with an approved extrusion machine. The extrusion machine shall be capable of shaping and thoroughly compacting the concrete to the required cross section.

The pavement shall be dry and cleaned of loose and deleterious material prior to curb placement. Cement concrete curbs shall be bonded to the existing pavement with an approved bonding agent to be approved by the Project Engineer prior to use, and anchored by placing steel reinforcing bars as shown in the contract plans.

Steel reinforcing bars shall meet the type and dimensions shown in the contract plans. Joints in the curb shall be spaced as shown in the contract plans. Joints shall be cut vertically and to the depth shown in the contract plans.

All other requirements for cement curb and cement concrete curb and gutter shall apply to extruded cement concrete curb.

## **APPENDIX A**

**Vendor Services Agreement,  
Endorsement Sample, Contract Bond,  
Prevailing Wage Acknowledgement, and  
Retainage Option – Informational Only**

## VENDOR SERVICES AGREEMENT

Skagit County, through the Department of \_\_\_\_\_ (hereinafter referred to as County) and \_\_\_\_\_ (hereinafter referred to as Contractor), for and in consideration of the mutual benefits do hereby agree as follows:

1. Contractor will provide the following service/products at such time and in such manner as described in **"Exhibit A"**.

2. County will compensate Contractor a maximum of \_\_\_\_\_, chargeable to GL expenditure code(s) # \_\_\_\_\_.

3. The parties agree that Contractor is an independent contractor, and not an employee nor agent of Skagit County. Contractor hereby agrees not to make any representations to any third party, nor to allow such third party to remain under the misimpression that Contractor is an employee of Skagit County. All payments made hereunder and all services performed shall be made and performed pursuant to this Agreement by the Contractor as an independent contractor. Contractor will defend, indemnify and hold harmless the County, its officers, agents or employees from any loss or expense, including but not limited to settlements, judgments, setoffs, attorneys' fees or costs incurred by reason of claims or demands because of breach of the provisions of this paragraph. Further the Contractor represents that all employees and sub-contractors are covered under Industrial Insurance in compliance with R.C.W. Title 51.

4. **Defense & Indemnity Agreement:**

The Contractor agrees to defend, indemnify and save harmless the County, its appointed and elective officers and employees, from and against all loss or expense, including but not limited to judgments, settlements, attorney's fees and costs by reason of any and all claims and demands upon the County, its elected or appointed officials or employees for damages because of personal or bodily injury, including death at any time resulting therefrom, sustained by any person or persons and on account of damage to property including loss of use thereof, whether such injury to persons or damage to property is due to the negligence of the Contractor, its subcontractors, its elected officers, employees or their agents, except only such injury or damage as shall have been occasioned by the sole negligence of the County, its appointed or elected officials or employees. It is further provided that no liability shall attach to the County by reason of entering into this contract, except as expressly provided herein.

5. This Contract shall commence on \_\_\_\_\_ and continue until either party terminates by giving 30 days notice in writing either personally delivered or mailed postage prepaid by certified mail, return receipt requested to the party's last known address, but in no event shall the contract continue for more than one year from date of execution.

6. The Contractor shall not assign any interest in this Contract and shall not transfer



any interest in same without prior written County consent.

7. The Contractor will secure, at his own expense, all personnel required in performing said services under this Contract. Contractor shall be personally liable for applicable payroll, labor and industries premiums and all applicable taxes and shall hold County harmless therefrom.

8. The Contractor shall provide proof of insurance for general comprehensive liability in the amount of \$1,000,000 to cover Contractor's activities during the term of this Contract. Proof of insurance shall be in a form acceptable and approved by the County. A certificate of insurance naming the County, its elected officials, and employees as additional insured's and naming the County as a certificate holder shall accompany this Contract for signing. Thirty (30) days' written notice to the County of cancellation of the insurance policy is required. No contract shall form until and unless a copy of the certificate of insurance, in the amount required, is attached hereto as set forth in **"Exhibit B"**. The contractor's insurance shall be primary. Any insurance or self-insurance maintained by the County, its officers, officials, employees or volunteers shall be excess of Contractor's insurance and shall not contribute to it.

9. **Prevailing Wages:**

Contractor and subcontractor shall submit a "Statement of Intent to Pay Prevailing Wages" prior to submitting first application for payment. Each statement of intent to pay prevailing wages must be approved by the Industrial Statistician of the Department of Labor and Industries before it is submitted to the County. Unless otherwise authorized by the Department of Labor and Industries, each voucher claim submitted by a Contractor for payment on a project estimate shall state that the prevailing wages have been paid in accordance with the pre-filed statement or statements of Intent to Pay Prevailing Wages on file with the public agency.

10. **Termination for Public Convenience:**

The County may terminate the contract in whole or in part whenever the County determines, in its sole discretion that such termination is in the best interests of the County. Whenever the contract is terminated in accordance with this paragraph, the Contractor shall be entitled to payment for actual work performed at unit contract prices for completed items of work. An equitable adjustment in the contract price for partially completed items of work will be made, but such adjustment shall not include provision for loss of anticipated profit on deleted or uncompleted work. Termination of this contract by the County at any time during the term, whether for default or convenience, shall not constitute a breach of contract by the County. If sufficient funds are not appropriated or allocated for payment under this contract for any future fiscal period, the County will not be obligated to make payments for services or amounts incurred after the end of the current fiscal period. No penalty or expense shall accrue to the County in the event this provision applies.

CONTRACTOR:

\_\_\_\_\_  
Signature & Title of Signatory  
(Date \_\_\_\_\_)

\_\_\_\_\_  
Print Name

\_\_\_\_\_  
Title

Mailing Address:

\_\_\_\_\_  
\_\_\_\_\_  
\_\_\_\_\_

Telephone No. \_\_\_\_\_

Fed. Tax ID # \_\_\_\_\_

Contractor Lic. #. \_\_\_\_\_

DATED this \_\_\_\_\_ day of \_\_\_\_\_, 2017.

**BOARD OF COUNTY COMMISSIONERS  
SKAGIT COUNTY, WASHINGTON**

\_\_\_\_\_  
Ron Wesen, Chair

\_\_\_\_\_  
Kenneth A. Dahlstedt, Commissioner

Attest:

\_\_\_\_\_  
Lisa Janicki, Commissioner

\_\_\_\_\_  
Clerk of the Board

For contracts under \$5,000:  
Authorization per Resolution R20030146

Recommended:

\_\_\_\_\_  
County Administrator

\_\_\_\_\_  
Department Head

Approved as to form:

\_\_\_\_\_  
Civil Deputy Prosecuting Attorney

Approved as to indemnification:

\_\_\_\_\_  
Risk Manager

Approved as to budget:

\_\_\_\_\_  
Budget & Finance Director

**EXHIBIT "A"**

**SCOPE OF SERVICES**

INFORMATIONAL ONLY

**EXHIBIT "B"**

**PROOF OF INSURANCE**

The Contractor shall provide proof of insurance for Commercial General Liability or Professional Liability in the amount of \$1,000,000.00 to cover Contractor's activities during the term of this Contract. Proof of insurance shall be in a form acceptable and approved by the County. Contractors insurance shall be primary.

The type of insurance required by this Agreement is marked below.

- 1) Commercial General Liability Insurance  
Certificate Holder – Skagit County  
**The Certificate must name the County as additional insured:  
Skagit County, its elected officials, officers and employees  
are named as additional insured.**  
Thirty (30) days written notice to the County of cancellation  
of the insurance policy.
- 2) Professional Liability  
Certificate Holder – Skagit County  
Thirty (30) days written notice to the County of cancellation  
of the insurance policy

NOTE: No contract shall form until and unless a copy of the Certificate of Insurance, properly completed and in the amount required, is attached hereto.

- 3) Insurance is waived

Date: \_\_\_\_\_  
Risk Manager

**THIS ENDORSEMENT CHANGES THE POLICY. PLEASE READ IT CAREFULLY.**

**ADDITIONAL INSURED – OWNERS, LESSEES OR  
CONTRACTORS – SCHEDULED PERSON OR  
ORGANIZATION**

This endorsement modifies insurance provided under the following:

COMMERCIAL GENERAL LIABILITY COVERAGE PART

**SCHEDULE**

Name Of Additional Insured Person(s) Or Organization(s):	Location(s) Of Covered Operations
Information required to complete this Schedule, if not shown above, will be shown in the Declarations.	

**A. Section II – Who Is An Insured** is amended to include as an additional insured the person(s) or organization(s) shown in the Schedule, but only with respect to liability for "bodily injury", "property damage" or "personal and advertising injury" caused, in whole or in part, by:

1. Your acts or omissions; or
2. The acts or omissions of those acting on your behalf;

in the performance of your ongoing operations for the additional insured(s) at the location(s) designated above.

**B.** With respect to the insurance afforded to these additional insureds, the following additional exclusions apply:

This insurance does not apply to "bodily injury" or "property damage" occurring after:

1. All work, including materials, parts or equipment furnished in connection with such work, on the project (other than service, maintenance or repairs) to be performed by or on behalf of the additional insured(s) at the location of the covered operations has been completed; or
2. That portion of "your work" out of which the injury or damage arises has been put to its intended use by any person or organization other than another contractor or subcontractor engaged in performing operations for a principal as a part of the same project.

## CONTRACT BOND

**KNOW ALL MEN BY THESE PRESENTS**, that Skagit County, a Municipal Corporation of Washington, has awarded

\_\_\_\_\_ of \_\_\_\_\_, as Principal, and \_\_\_\_\_ as Surety, are jointly and severally held and bound unto the County of Skagit in the penal sum of \_\_\_\_\_ (\$ \_\_\_\_\_), dollars, for the payment of which we jointly and severely bind ourselves, our heirs, executors, administrators, and assigns, and successors and assigns, firmly by these presents.

**THE CONDITION** of this bond is such that whereas, on the \_\_\_\_\_ day of \_\_\_\_\_ A.D., 2017, the said Principal, herein, executed a certain contract with the County of Skagit by the items, conditions and provisions of which contract the said \_\_\_\_\_, Principal, herein agree to furnish all material and do certain work, to wit: That \_\_\_\_\_ will undertake and complete the

### **Maintenance of Restoration Projects within Skagit County**

according to the maps, plans and specifications made a part of said contract, which contract as so executed, is hereunto attached, is now referred to and by reference is incorporated herein and made a part hereof as fully for all purposes as if here set forth at length. The bond shall cover all approved change orders as if they were in the original contract.

**NOW, THEREFORE**, if the Principal herein shall faithfully and truly observe and comply with the terms, conditions and provisions of said contract in all respects and shall well and truly and fully do and perform all matters and things by \_\_\_\_\_ (principal) undertaken to be performed under said contract, upon the terms proposed therein, and within the time prescribed therein, and until the same is accepted, and shall pay all laborers, mechanics, subcontractors and material men, and all persons who shall supply such contractor or subcontractor with provisions and supplies for the carrying on of such work, and shall in all respects faithfully perform said contract according to law, then this obligation to be void, otherwise to remain in full force and effect.

**WITNESS** our hands this \_\_\_\_\_ day of \_\_\_\_\_, 2017.

\_\_\_\_\_  
\_\_\_\_\_  
\_\_\_\_\_

(Principal)

\_\_\_\_\_  
\_\_\_\_\_  
\_\_\_\_\_  
Attorney-in-Fact, Surety

\_\_\_\_\_  
Name and Address  
Local Office of Agent

APPROVED AS TO FORM  
RICH WEYRICH  
Skagit County Prosecuting Attorney

APPROVED AS TO FORM  
JESSICA NEILL HOYSON  
Skagit County Risk Manager

BY: \_\_\_\_\_  
Approving Authority

DATE: \_\_\_\_\_, 2017

\_\_\_\_\_  
SURETY BOND NUMBER

\_\_\_\_\_  
CONTRACT NUMBER

\_\_\_\_\_

\_\_\_\_\_



# PREVAILING WAGE ACKNOWLEDGMENT

We, **\*\*Insert Co. Name\*\***, the undersigned vendor acknowledge State of Washington prevailing wage rates are applicable for this public works project: Blanchard Quite Zone within Skagit County.

Dated: \_\_\_\_\_

Signed by: \_\_\_\_\_  
(Name & Title)

---

Attention Sole Proprietors, Partners & Officer/Owners:

- Sole owners of their own businesses who perform the actual work themselves are not required to pay themselves the prevailing wage rates.
- Partners in a partnership who own at least 30% of a company are likewise not required to pay themselves prevailing wage rates.
- The President, Vice President, and Treasurer of a corporation are not required to pay themselves prevailing wage, as long as each owns at least 30% of the corporations.

These companies are not exempt from the remaining requirements of the statute, including the filing of Intent and Affidavit forms. Any worker who owns less than 30% of the company is not exempt and must be paid the prevailing wage rate. WAC 296-127-026.



# SKAGIT COUNTY PUBLIC WORKS DEPARTMENT

1800 Continental Place, Mount Vernon, WA 98273-5625  
(360) 416-1400 FAX (360) 416-1405

## DECLARATION OF OPTION FOR MANAGEMENT OF STATUTORY RETAINED PERCENTAGE

*Note: This form must be submitted at the time the Contractor executes the contract. Contractor shall designate the option desired by checking the appropriate space.*

Monies reserved under provisions of **Chapter 60.28 RCW**, at the option of the Contractor, shall be:

- 1. I hereby elect to have the retained percentage of this contract held in a fund by Skagit County in a non-interest bearing account.
- 2. I hereby elect to have Skagit County deposit the retained percentage of this contract in an interest bearing account, not subject to withdrawal until after final acceptance of the work.

I hereby further agree to open the interest-bearing account in a qualified financial institution. I further agree to provide instructions to the bank to provide Skagit County Public Works with a monthly account statement to the attention of the Project Manager. Prior to Skagit County depositing any funds into the account, the CONTRACTOR shall obtain a letter from the financial institution on their letterhead stating the account number and bank address and confirming they will not release any funds until authorized in writing by Skagit County.

- 3. I hereby elect to have Skagit County invest the retained percentage of this contract from time to time as such retained percentage accrues.

I hereby designate \_\_\_\_\_ as the repository for the escrow of said funds.

I hereby further agree to be fully responsible for payment of all costs or fees incurred as a result of placing said retained percentage in escrow and investing it as authorized by statute.

Skagit County shall not be liable in any way for any costs or fees in connection therewith. Prior to Skagit County investing any funds in an escrow account, the CONTRACTOR shall obtain an escrow agreement from the repository stating their acceptance of the account, the account number and a statement that they will not release any funds until authorized in writing by Skagit County. Additionally, Skagit County Public Works will require a monthly statement from the bank for the escrow account.

- 4. I hereby elect to obtain a Retainage Bond acceptable to Skagit County, and agree to provide the original bond to the County. I acknowledge that no retainage will be held by Skagit County from the CONTRACTOR when Skagit County has received an acceptable bond.

The Contractor in choosing option (2) or (3) agrees to assume full responsibility to pay all costs which may accrue from escrow services, brokerage charges or both, and further agrees to assume all risks in connection with the investment of the retained percentages in securities.

\_\_\_\_\_  
Company Name

\_\_\_\_\_  
Date

\_\_\_\_\_  
Authorized Signature

\_\_\_\_\_  
Title

\_\_\_\_\_  
Print Name

\_\_\_\_\_  
Phone Number

## **APPENDIX B**

### **Proposal Forms – Informational Only**

# Proposal For Bidding Purposes

**Blanchard Quiet Zone Median Curb  
Construction Project #ES20830-3, ES20830-3A**

**SMALL PUBLIC WORKS PROJECT  
SKAGIT COUNTY PUBLIC WORKS**

**Must be an approved contractor on the Municipal Research and  
Services Center (MRSC) Roster in order to Bid this project:  
<http://www.mrscrosters.org>**

---



SKAGIT COUNTY  
Public Works Department  
1800 Continental Place  
Mount Vernon, WA 98273

## BID PROPOSAL

### Blanchard Quiet Zone Median Curb Construction

Skagit County, Washington

2017 - 2019

**\*\* ENTIRE PROPOSAL TO BE RETURNED AS YOUR BID PACKAGE \*\***

MUST BE AN APPROVED CONTRACTOR ON THE MUNICIPAL RESEARCH AND SERVICES CENTER (MRSC) ROSTER IN ORDER TO BID THIS PROJECT: <http://www.mrscrosters.org>

All bid envelopes must be plainly marked on the outside, "**Sealed Bid: Blanchard Quiet Zone**"

**BID DUE DATE AND TIME:** Friday, December 8, 2017 at 3:30 p.m.

Late and/or incomplete bids will not be considered. Oral, telephonic, telegraphic, electronic, or faxed proposals will not be accepted.

Sealed Bids will be accepted at the following location by one of the following delivery methods:

**Bids May be Hand-Delivered or Mailed to:**

Skagit County Commissioners Office  
Attn: Reception Desk  
Sealed Bid: **Blanchard Quiet Zone**  
1800 Continental Place  
Mount Vernon, WA 98273

**FAILURE TO SIGN OR COMPLETE ALL INFORMATION ON THE FORMS PROVIDED CAN RESULT IN REJECTION OF THE PROPOSAL AS NON-RESPONSIVE**

**CONDITION OF AWARD:**

It is the intent of Skagit County to award a contract to the low responsive and responsible bidder. All terms and conditions listed in the Contract Provisions and Specifications apply to this condition.

**MANDATORY BIDDER CRITERIA:**

Before award, the bidder must meet the following bidder responsibility criteria to be considered a responsible bidder. The bidder may be required by Skagit County to submit documentation demonstrating compliance with the criteria. The bidder must:

1. Have a current certificate of registration as a contractor in compliance with chapter 18.27 RCW, which must have been in effect at the time of bid submittal.
2. Have a current Washington Unified Business Identifier (UBI) number.
3. Have Industrial Insurance (workers' compensation) coverage for the bidder's employees working in Washington, as required in Title 51 RCW. Not applicable to sole proprietors if the owner performs work himself/herself.
4. Have a Washington Employment Security Department number (ESD), as required in Title 50 RCW **(and, if the lowest responsive and responsible bidder, provide documentation from ESD in the form of a letter or statement within 24 hours of submitting bid);**
5. Have a Washington Department of Revenue state excise tax registration number, as required in Title 82 RCW;
6. Not be disqualified from bidding on any public works contract under RCW 39.06.010 or 39.12.065(3) and;
7. Not be excluded or suspended from bidding on any public works contract under federal laws.

**SCHEDULE:**

Contractor shall not commence work until notice to proceed has been given by Skagit County; this occurs after the Contract has been executed by Skagit County Board of County Commissioners.

**PAYMENT:**

Invoices can be submitted after work is performed. Payment is made when the Contractor has filed his/her "Intent to Pay Prevailing Wages" with the Washington State Department of Labor and Industries. Final payment is made when the Contractor has filed his/her "Affidavit of Paying Prevailing Wages".

**FAILURE TO SIGN OR COMPLETE ALL INFORMATION ON THE FORMS PROVIDED CAN RESULT IN REJECTION OF THE PROPOSAL AS NON-RESPONSIVE**

This certifies that the undersigned has examined the entire bid proposal and contract provisions and specifications for the:

**Blanchard Quiet Zone Median Curb Construction**

and the contract governing the work embraced in this project, and the method by which payment will be made for said work, is understood. The undersigned hereby proposes to undertake and complete the work, or as much thereof as can be completed with the money available in accordance with the said description of work and contract, and the following schedule of rates and prices. Bidder acknowledges all requirements and signed all certificates contained herein. Bidder agrees to pay labor not less than the prevailing rates of wages in accordance with the requirements of the special provisions for this project.

<b>Blanchard Quiet Zone Median Curb Construction</b>					
<b>Item Number</b>	<b>Description</b>	<b>Qty.</b>	<b>Unit</b>	<b>Unit Price</b>	<b>Total Cost</b>
1	Dual-Faced Cement Conc. Traffic Curb	560	LF		
Subtotal:					
GRAND TOTAL:					

Please use ink, print legibly, and initial and date any changes, erasures, or cross-outs. All unit prices, when relevant, are mandatory and shall control.

**FAILURE TO SIGN OR COMPLETE ALL INFORMATION ON THE FORMS PROVIDED CAN RESULT IN REJECTION OF THE PROPOSAL AS NON-RESPONSIVE**

INFORMATION

**PROPOSAL – Signature Page**

The bidder is hereby advised that by signature of this proposal he/she is deemed to have acknowledged all requirements and signed all certificates contained herein.

The undersigned hereby agrees to pay labor not less than the prevailing rates of wages in accordance with the requirements of the special provisions for this project.

A proposal guaranty in an amount, which is equal to five percent (5%) of the estimated bid amount, based upon the approximate estimate of above prices and in the form as indicated below is attached hereto:

- CASHIER'S CHECK      In the amount of \$ \_\_\_\_\_ Dollars
- CERTIFIED CHECK      In the amount of \$ \_\_\_\_\_ Dollars  
(Payable to Skagit County)
- PROPOSAL BOND      In the amount of five percent (5%) of the total estimated contract amount.

If addendums have been issued:  
Receipt is hereby acknowledged of Addendum(s) No.(s) \_\_\_\_\_

**S  
I  
G  
N**

**Signature of Authorized Official(s):**

\_\_\_\_\_  
\_\_\_\_\_

Firm Name: \_\_\_\_\_

Address: \_\_\_\_\_  
\_\_\_\_\_

Phone No. \_\_\_\_\_

State of Washington Contractor's License No. \_\_\_\_\_

UBI No. \_\_\_\_\_ Employment Security Department No. \_\_\_\_\_

**Note:**

- (1) This proposal form is not transferable and any alteration of the firm's name entered hereon without prior permission from the Skagit County will be cause for considering the proposal irregular and subsequent rejection of the bid.
- (2) Please refer to Section 1-02.6 of the Standard Specifications, "Preparation of Proposal", or "Article 4" of the Instruction to Bidders for building construction jobs.

**FAILURE TO SIGN OR COMPLETE ALL INFORMATION ON THE FORMS PROVIDED CAN RESULT IN REJECTION OF THE PROPOSAL AS NON-RESPONSIVE**



# NON-COLLUSION DECLARATION

I, by signing the proposal on page 5, hereby declare, under penalty of perjury under the laws of the United States that the following statements are true and correct:

1. That the undersigned person(s), firm, association or corporation has (have) not, either directly or indirectly, entered into any agreement, participated in any collusion, or otherwise taken any action in restraint of free competitive bidding in connection with the project for which this proposal is submitted.
2. That by signing the signature page of this proposal, I am deemed to have signed and have agreed to the provisions of this declaration.

## NOTICE TO ALL BIDDERS

To report bid rigging activities call:

**1-800-424-9071**

The U.S. Department of Transportation (USDOT) operates the above toll free 'hotline' Monday through Friday, 8:00 a.m. to 5:00 p.m., Eastern Standard Time. Anyone with knowledge of possible bid rigging, bidder collusion, or other fraudulent activities should use the 'hotline' to report such activities.

The 'hotline' is part of USDOT's continuing effort to identify and investigate highway construction fraud and abuse and is operated under the direction of the USDOT Inspector General. All information will be treated confidentially and caller anonymity will be respected.

**MUST ACCOMPANY EACH BID**

**FAILURE TO SIGN OR COMPLETE ALL INFORMATION ON THE FORMS PROVIDED CAN RESULT IN REJECTION OF THE PROPOSAL AS NON-RESPONSIVE**

## NON-DISBARMENT CERTIFICATION

Are you on Comptroller General's list of Ineligible Contractors or list of parties excluded from Federal procurement or non-procurement programs?  NO  YES

Company Name: \_\_\_\_\_

Type of Business     Corporation     Partnership (general)     Partnership (limited)  
 Sole Proprietorship                       Limited Liability Company

FID #: \_\_\_\_\_

Company Address: \_\_\_\_\_

The County/State/Zip: \_\_\_\_\_

Phone: \_\_\_\_\_ Fax: \_\_\_\_\_

E-Mail: \_\_\_\_\_

Print Name of Signatory: \_\_\_\_\_

Print Title of Signatory: \_\_\_\_\_

INFORMATIONAL ONLY

**MUST ACCOMPANY EACH BID**

**FAILURE TO SIGN OR COMPLETE ALL INFORMATION ON THE FORMS PROVIDED CAN RESULT IN REJECTION OF THE PROPOSAL AS NON-RESPONSIVE**

**SUBMIT THE  
ENCLOSED PROPOSAL  
BOND FORM WITH  
YOUR PROPOSAL**

**USE OF OTHER FORMS  
MAY SUBJECT YOUR  
BID TO REJECTION**

INFORMATIONAL ONLY

**PROPOSAL BOND**

KNOW ALL MEN BY THESE PRESENTS, That we, \_\_\_\_\_

\_\_\_\_\_ of  
\_\_\_\_\_ as principal, and the  
\_\_\_\_\_ a corporation duly

organized under the laws of the State of \_\_\_\_\_,  
and authorized to do business in the State of Washington, as surety, are held and firmly bound unto Skagit  
County in the full and penal sum of five (5) percent of the total amount of the bid proposal of said principal  
for the work hereinafter described for the payment of which, well and truly to be made, we bind our heirs,  
executors, administrators and assigns, and successors and assigns, firmly by these presents.

The condition of this bond is such, that whereas the principal herein is herewith submitting his or its  
sealed proposal for the following construction, to wit:

**Blanchard Quiet Zone Median Curb Construction**

said bid and proposal, by reference thereto, being made a part hereof.

NOW THEREFORE, If the said proposal bid by said principal be accepted, and the contract be  
awarded to said principal, and if said principal shall duly make and enter into and execute said contract and  
shall furnish bond as required by Skagit County within a period of ten (10) days from and after said award,  
exclusive of the day of such award, then this obligation shall be null and void, otherwise it shall remain and  
be in full force and effect.

IN TESTIMONY WHEREOF, The principal and surety have caused these presents to be  
signed and sealed this \_\_\_\_\_ day of \_\_\_\_\_, 2017.

\_\_\_\_\_  
(Principal)

\_\_\_\_\_  
(Surety)

\_\_\_\_\_  
(Attorney-in-fact)



## Certification of Compliance with Wage Payment Statutes

The bidder hereby certifies that, within the three-year period immediately preceding the bid solicitation date September 25, 2017, the bidder is not a "willful" violator, as defined in RCW 49.48.082, of any provision of chapters 49.46, 49.48, or 49.52 RCW, as determined by a final and binding citation and notice of assessment issued by the Department of Labor and Industries or through a civil judgment entered by a court of limited or general jurisdiction.

I certify under penalty of perjury under the laws of the State of Washington that the foregoing is true and correct.

\_\_\_\_\_  
Bidder's Business Name

\_\_\_\_\_  
Signature of Authorized Official\*

\_\_\_\_\_  
Printed Name

\_\_\_\_\_  
Title

\_\_\_\_\_  
Date

\_\_\_\_\_  
City

\_\_\_\_\_  
State

Check One:

Sole Proprietorship  Partnership  Joint Venture  Corporation

State of Incorporation, or if not a corporation, State where business entity was formed:

\_\_\_\_\_  
If a co-partnership, give firm name under which business is transacted:

\_\_\_\_\_  
*\* If a corporation, proposal must be executed in the corporate name by the president or vice-president (or any other corporate officer accompanied by evidence of authority to sign). If a co-partnership, proposal must be executed by a partner.*

# **APPENDIX C**

## **Plans**